

INFORMATION PAPER

COLLISION PREVENTION AT PORTS & TERMINALS

A joint initiative from TT Club, ICHCA International and the Port Equipment Manufacturers Association

© TT Club, ICHCA International and Port Equipment Manufacturers Association



TT CLUB 

ICHCA
INTERNATIONAL

PEMA
PORT EQUIPMENT MANUFACTURERS ASSOCIATION



TABLE OF CONTENTS

BACKGROUND & INTRODUCTION	4
DISCLAIMER	4
ABOUT PEMA	5
ABOUT TT CLUB	5
ABOUT ICHCA INTERNATIONAL	6
NOTE	6
COLLISION TYPES	7
COLLISION PREVENTION AT PORTS & TERMINALS	8
APPLICATION SOLUTIONS AND FEATURES	8
SHIP TO SHORE CRANE (STS) – COLLISION PREVENTION SOLUTIONS	8
NON-CONTACT BOOM & CRANE TO CRANE COLLISION PREVENTION (RISK REDUCTION)	10
ELECTRONIC TRAVEL COLLISION PREVENTION (RISK REDUCTION)	12
VESSEL PROFILING, LOAD COLLISION PREVENTION (RISK REDUCTION)	13
SAFE ACCESS GUARDING AT LASHING PLATFORM (SAFETY)	14
GANTRY CRANE – COLLISION PREVENTION SOLUTIONS	15
RAIL MOUNTED GANTRY (RMG), AUTOMATED STACKING CRANE (ASC) COLLISION	15
ELECTRONIC TRAVEL COLLISION PREVENTION (RISK REDUCTION)	16
CONTAINER STACK PROFILING, LOAD COLLISION PREVENTION (RISK REDUCTION)	16
ASC TRANSFER AREA ACCESS GUARDING (RISK REDUCTION)	17
ANTI-TRUCK LIFTING (RISK REDUCTION)	20
RUBBER TYRED GANTRY CRANE (RTG) – COLLISION PREVENTION SOLUTIONS	21
(RTG) PATHWAY & CROSS TRAVEL COLLISION PREVENTION (RISK REDUCTION)	22
STRADDLE CARRIER (SC) – COLLISION PREVENTION SOLUTIONS	23
(SC) PATHWAY & CROSS TRAVEL COLLISION PREVENTION (RISK REDUCTION)	24
HEAVY LIFT TRUCK – COLLISION PREVENTION SOLUTIONS	25
REACH STACKER REAR DRIVE COLLISION PREVENTION (RISK REDUCTION)	26
AUTOMATED GUIDED VEHICLE (AGV) - COLLISION PREVENTION SOLUTIONS	27
NON-CONTRACT TRAVEL COLLISION PREVENTION (RISK REDUCTION)	28
TECHNOLOGIES FOR COLLISION PREVENTION IN PORTS & TERMINALS	29
LASER TECHNOLOGY	29
THE NEED FOR ROBUST EQUIPMENT	??
RADAR TECHNOLOGY	??
3D SENSOR WITH 2D STEREO CAMERA TECHNOLOGY	??
ACTIVE RFID TECHNOLOGY	??
ULTRASONIC TECHNOLOGY	??
MECHANICAL INSTALLATIONS FOR COLLISION PREVENTION IN PORTS	38
ABOUT THE AUTHORS	39

BACKGROUND & INTRODUCTION COLLISION PREVENTION AT PORTS AND TERMINALS

In a bid to improve safety, reduce injuries and loss of life, equipment damage and minimize costly business disruption at ports and terminals worldwide, PEMA, TT Club, and ICHCA International have pooled resources to make available information to promote collision prevention. The results of this research and consultation fall under the auspices of PEMA's Safety & Environment Committee.

All relevant stakeholders have been involved in the development of this project. PEMA represents container crane and technology suppliers, and TT Club and ICHCA International represent container terminals.

There are a growing number of non-contact, state-of-the-art technologies for collision prevention that can dramatically improve equipment safety and reduce risk associated with container handling. However, many of these are not currently included in national or international standards. This paper suggests that such technologies should be installed on new and existing equipment.

DISCLAIMER

The collision prevention at Ports and Terminals content has been jointly developed by PEMA, TT Club and ICHCA International according to information available at the time of publication. It does not constitute professional advice, nor is it an exhaustive summary of the information available on the subject matter to which it refers.

This paper covers major features and types of non-contact technologies for collision prevention at ports and terminals.

This information does not carry any force of law, and is independent of the various local, national and international regulatory regimes on the safe design, manufacture, specification and operation of the various equipment types, which must also be satisfied. Adoption of equipment technologies to enhance risk reduction and safety, which is the primary focus of this document, must also go together with the development of robust operational safety processes.

This document should always be read and used in conjunction with the relevant national and international legislation and any applicable regulations, standards and codes of practice. Every effort is made to ensure the accuracy of the information but neither PEMA, TT Club, ICHCA International, nor any of their members is responsible for any loss, damage, costs or expenses incurred (whether in negligence or not) arising from reliance on or interpretation of the information.

ABOUT PEMA



The Port Equipment Manufacturers Association (PEMA) was established in 2004 to provide a forum and public voice for the global port equipment and technology sectors, reflecting their critical role in enabling safe, secure, sustainable and productive ports, and thereby supporting world maritime trade.

Chief among the aims of the Association is to foster good relations within the world port equipment and technology community, by providing a forum for the exchange of views on trends in design, manufacture and operation of port equipment and technology.

PEMA also promotes and supports the global role of port equipment and technology by raising awareness

with customers, the media and other stakeholders; forging relations with other port industry associations and bodies; and contributing to best practice initiatives and information.

PEMA's growing membership represents a cross-section of port equipment OEMs, suppliers of components including brakes, cable reels, controls, drive systems, tyres and more, providers of software, systems and other advanced technologies, and expert consultants in the field of port equipment and technology.

pema.org

ABOUT TT CLUB



TT Club is the international transport and logistics industry's leading provider of insurance and related risk management services. Established in 1968, the Club's membership comprises vessel operators, ports and terminals, road, rail and airfreight operators, logistics companies and container lessors.

As a mutual insurer, the Club exists to provide its policyholders with benefits, which include specialist underwriting expertise, a worldwide office network providing claims management services, and first class risk management and loss prevention advice.

ttclub.com

ABOUT ICHCA INTERNATIONAL

ICHCA International is the only global association dedicated to the promotion of safety and efficiency in the handling and movement of goods by all modes and throughout the supply chain.

Originally established in 1952 and incorporated in 2002, the Association operates through a series of Local, National and Regional Chapters, Panels, Working Groups and Correspondence Groups and represents the cargo handling world at various international organizations, including the International Maritime Organization (IMO), United Nations Conference on Trade and Development (UNCTAD), International Labour Organization (ILO) and the International Organization for Standardization (ISO).

ICHCA International members include ports, terminals, transport companies and other groups associated with cargo handling and coordination. Members of its Panels represent a substantial cross-section of senior experts and professionals from all sectors of the cargo transport industry globally.

Members benefit from consulting services and informative publications dealing with technical matters, best practice advice and cargo handling news.

ichca.com

NOTE:

Collision prevention should be a general requirement for all equipment types. In all cases, obstacles should be monitored in the direction of travel for the full width of the equipment and its attachments.

An emergency stop should be a general requirement for all large equipment types. It is a basic safety requirement on all such machines and should be clearly labelled to identify it.

Other simple measures can be taken to segregate plant, equipment and personnel such as traffic flow marking, concrete and other barriers, signage and of course information, instruction and training. These measures are supplementary to technological solutions.

COLLISION TYPES

Container terminals are inherently associated with potential safety risk, with vehicles and heavy equipment operating in close proximity. However, given that terminal plant is broadly similar and typically performs similar tasks, it is possible to model different types of collisions and place them in a matrix. To determine what may occur in each part of a terminal, this paper specifies the equipment and personnel likely to be involved in each area; and for each combination of machinery and personnel, the document analyzes possible collision types. When a given collision type could occur in more than one area, solutions are not repeated but a reference is shown.

MAIN TERMINAL AREAS

Quay:

- Docking area
- Loading/discharging area

Yard:

- Yard container stack area
- On-dock rail terminal (intermodal)
- Repair and maintenance area
- Vehicle reception area

QUAY

Involved equipment:

- Vessel
- STS crane
- Ground transportation vehicles (trucks, terminal tractor, lift trucks, AGVs)

Personnel:

- Lashing personnel
- Vessel crew
- Truck and terminal tractor drivers
- Container handling equipment drivers
- Pin men
- Tallymen
- Maintenance and service staff

COLLISION PREVENTION AT PORTS & TERMINALS

APPLICATION SOLUTIONS AND FEATURES

SHIP TO SHORE CRANE (STS) – COLLISION PREVENTION SOLUTIONS

ISSUES		
DANGEROUS ITEM		
STS CRANE		
OBSTACLE	STS crane	Hitting adjacent crane Hitting container handling equipment
	Vessel	Hitting vessel with boom Hitting stack with spreader
	Lashing personnel	Hitting a person with spreader Dropping
	Stacked Container	Hitting stack with spreader

SOLUTIONS		
Issue	Feature	Technologies
Hitting vessel with boom	Non-contact boom collision prevention	2D laser scanner Radar Sensor*
Hitting adjacent crane Hitting container handling equipment	Electronic travel collision prevention Electronic crane to crane collision prevention	1D laser Sensor * Radar sensor* 2D laser scanner 2D*
Hitting the pile with spreader	Vessel profiling, load collision prevention	2D laser scanner 3D laser scanning system
Hitting personnel with spreader	At lashing platform: safety access guarding	Multi-safety light beam 2D laser scanner Safety Interlock Personnel tracking technology (active or passive safety tag system)
Dropping personnel with spreader	Lashing area under STS: safety monitoring/tracking of personnel(lashers) to ensure safe distance from hazardous movements	Personnel tracking technology (active or passive safety tag system)

* depending on equipment type

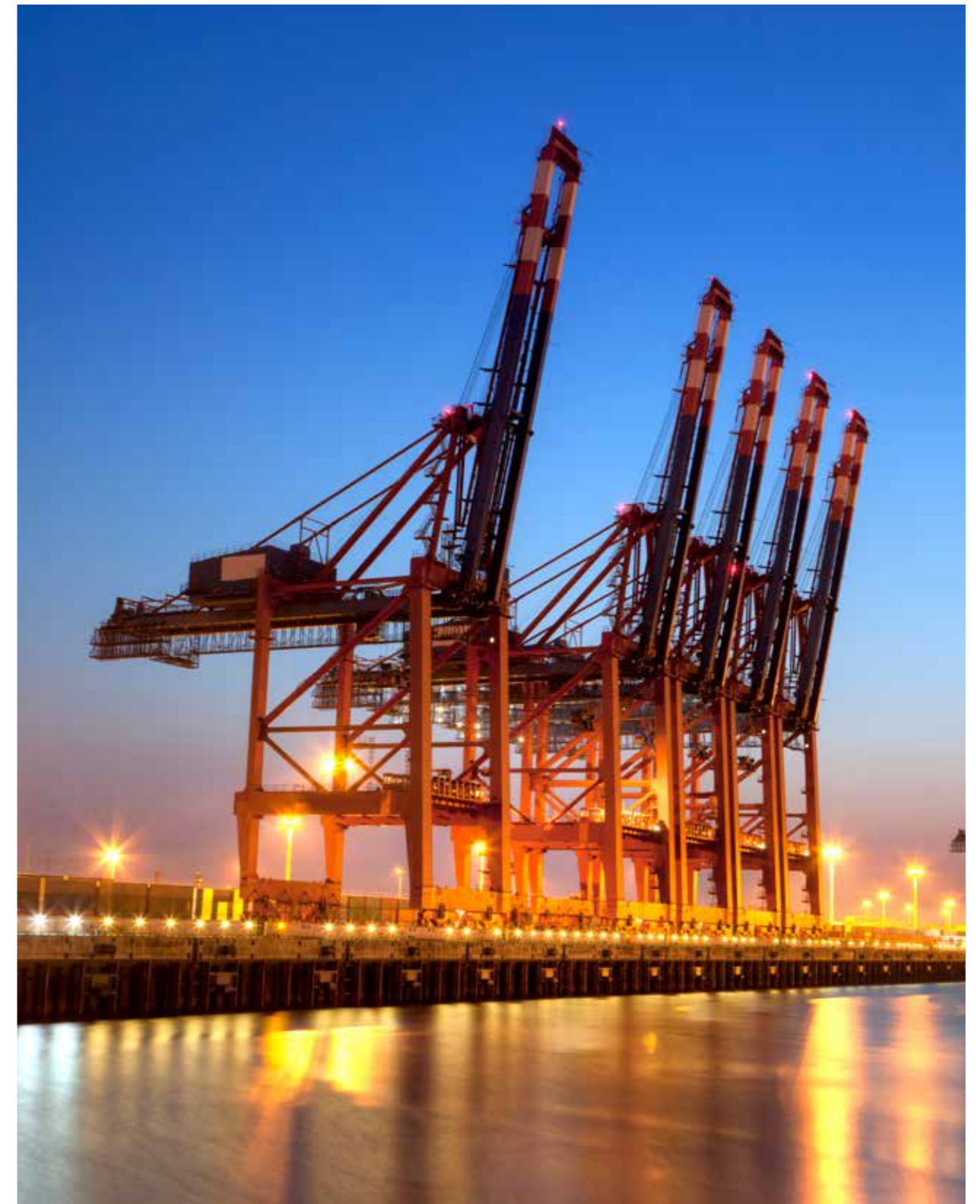

NON-CONTACT BOOM AND CRANE TO CRANE COLLISION PREVENTION (RISK REDUCTION)

Feature	Technology
Boom collision prevention and crane-to-crane collision prevention	Laser Scanner 2D

To avoid collisions between the crane boom and vessel superstructure, a system for advanced object detection based on 2D laser scanners combined with a safety controller can be installed in such a way that horizontal surveillance fields are set next to/around the boom. If any structures are detected in the surveillance fields during the crane's gantry drive, a

warning will sound as an alarm signal and/or a slowdown of movement or, in emergency cases, a stop will be generated. Due to its multiple field sets, the laser scanner system ensures collision prevention for the boom as well as for crane-to-crane simultaneously.

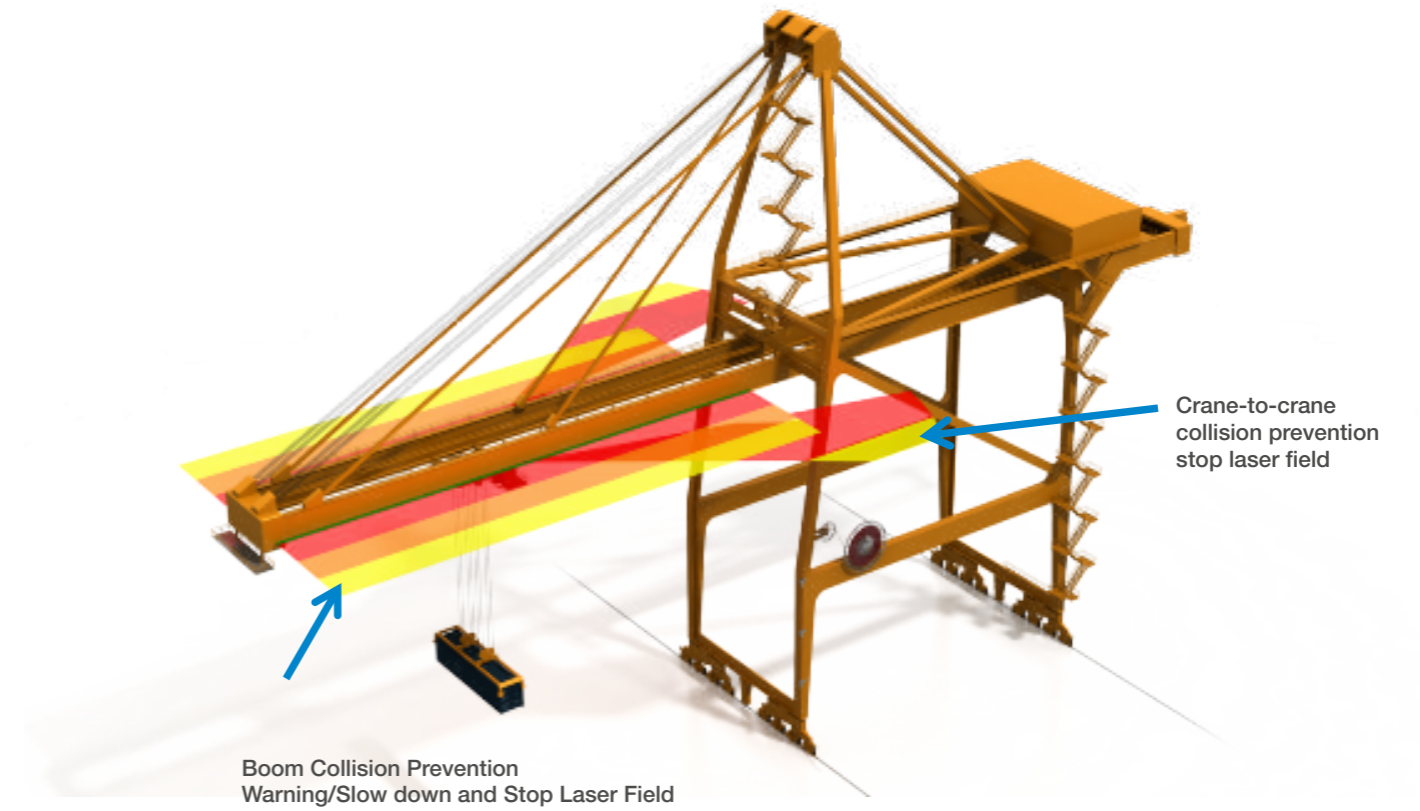
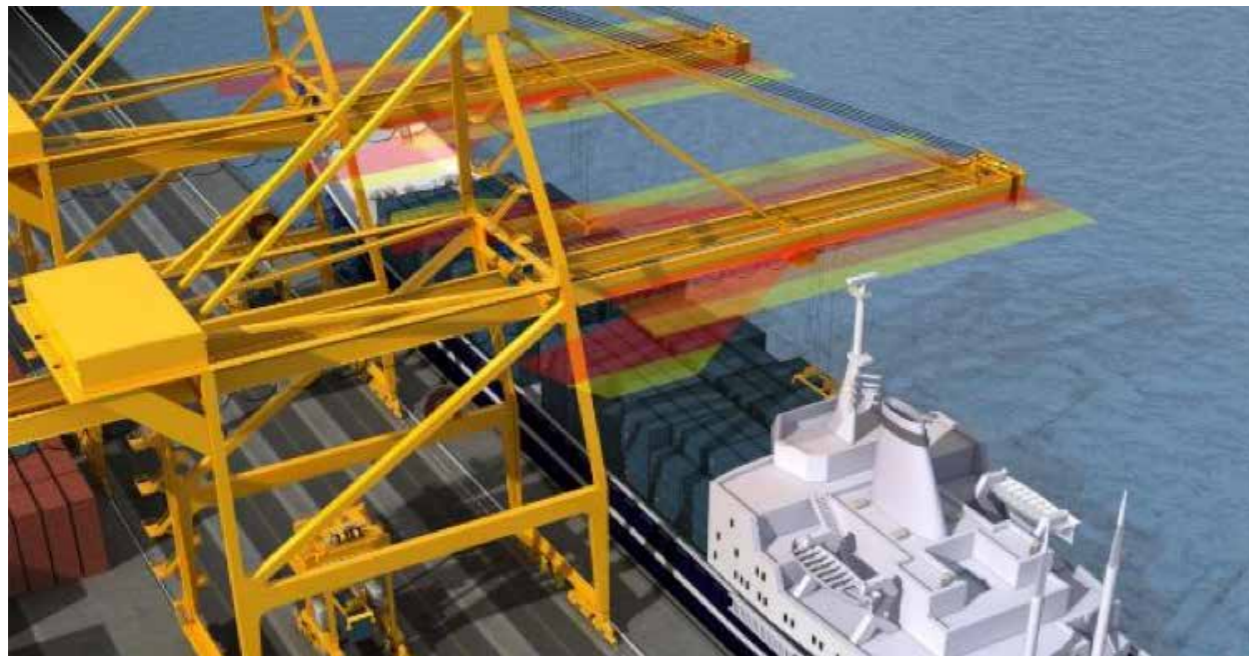

Via automatic self-testing cycles, laser scanner systems provide a high diagnostic coverage for boom and crane-to-crane collision prevention. Advanced systems provide cover for boom dimensions of the

latest STS cranes used with Triple-E Class vessels by, for example, installing a laser scanner on each side of the boom.

ELECTRONIC TRAVEL COLLISION PREVENTION (RISK REDUCTION)

Feature	Technology
STS Travel Collision Prevention	2D laser scanner 1D Laser distance measurement sensor * Radar sensor*

(* depending on the equipment type)

For uninterrupted operation, and to reduce the likelihood of collision between STS cranes and obstacles, an electronic non-contact collision prevention system is mandatory. Due to the importance of detecting adjacent cranes, the ability to signal critical distances between cranes via simple alarm outputs from distance sensors is critical. This can be achieved with single-beam laser sensors mounted on the gantry and directed to the adjacent crane. Laser sensors should be able to set alarm thresholds at ranges of about 20m to 30m to match crane stopping distances.

A radar sensor is suitable for sending alarm signals at defined distances, and providing independent alarm outputs for different distance settings.

To process measured distance values effectively, for example to position cranes or approaching cranes in

defined positions, a time-of-flight laser or single-beam long-range distance sensor are recommended. Along with alarm signals at switching outputs at critical distances, the actual distance, to an adjacent crane is also available via analogue output.

For greater diagnostic coverage, a system for advanced object detection based on 2D laser scanners, combined with a safety controller, can be installed. Along with pre-configured warning and stopping fields for slowdown and crane stop, the system performs automatic self-tests to verify correct sensor function, for example detectability, correct switching action and wire breakages. By placing a laser scanner on each wheel bogie of the crane, collision prevention of crane-to-crane and monitoring the pathway regarding obstacles can be combined.

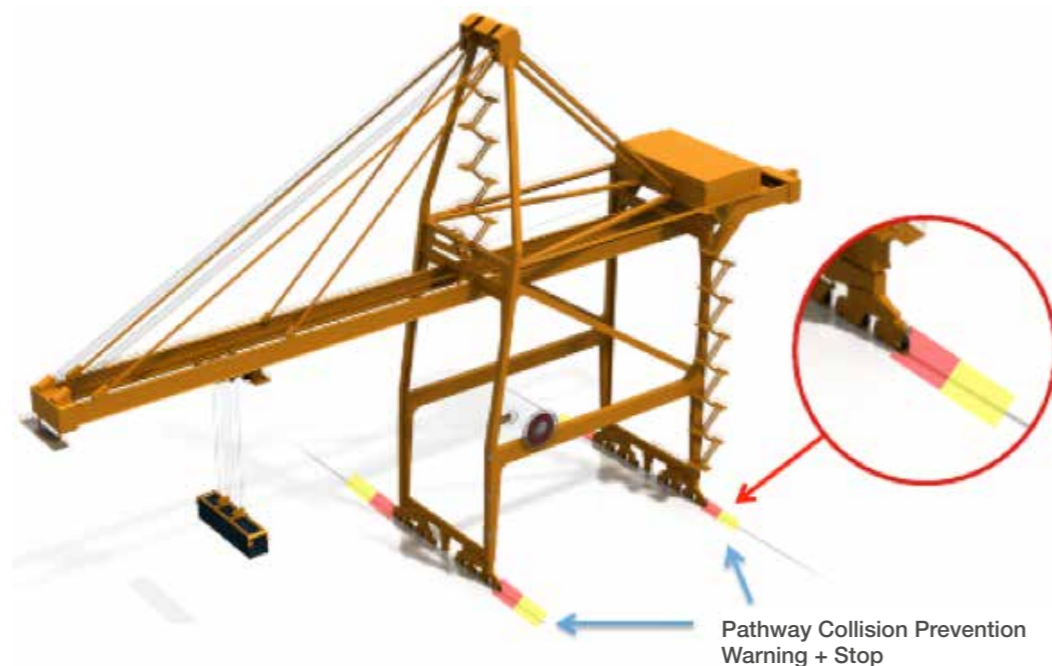

VESSEL PROFILING, LOAD COLLISION PREVENTION (RISK REDUCTION)

Feature	Technology
Vessel profiling/STS load collision prevention	2D laser scanner 3D laser scanning system

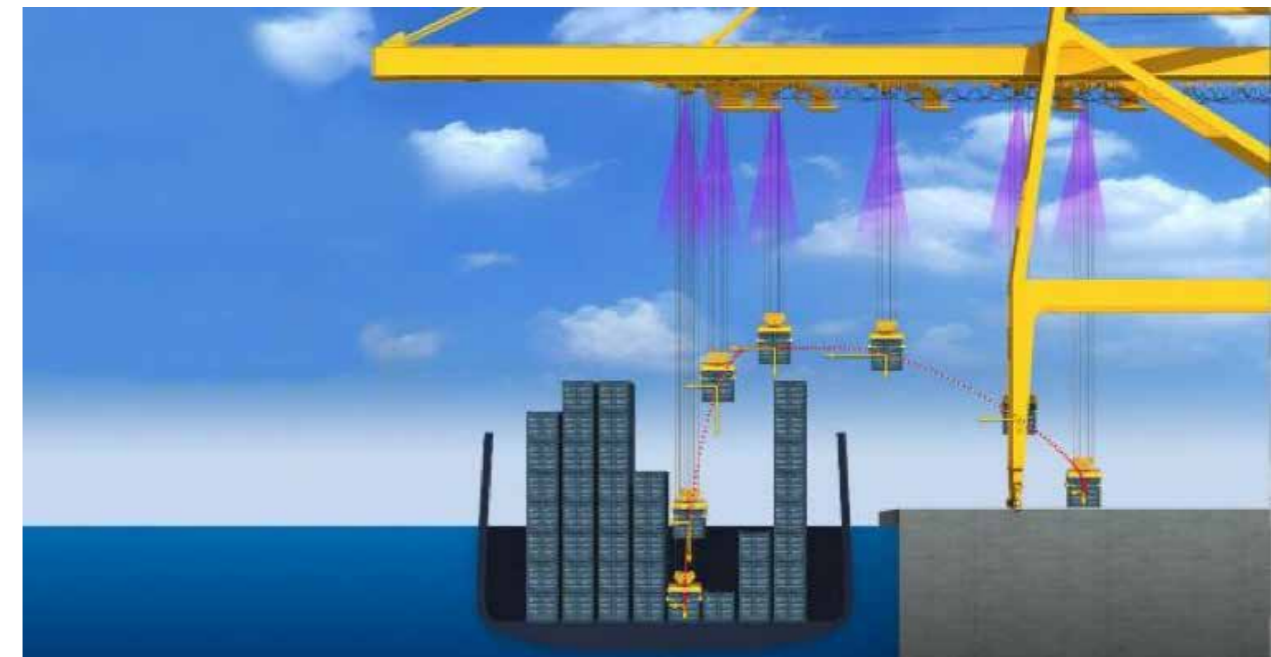

A 2D long-range laser scanner installed on the trolley facilitates spreader positioning at container bays on ships, and reduces the risk of collision. The trolley position, combined with the distance values of the laser scanner, shows a dynamic 2D-profile of the actual load situation. The generated data, along with the spreader position, assists the crane driver in faster and safer container handling. The 2D laser scanner allows measurement on very dark coloured containers up to distances of 80m.

An external control software system uses the stack profile information for a safer spreader drive over the bay, further creating a safe landing system through the control of the hoist speed and actual spreader position.

Collision prevention functionality based on profiling information, as well as a landing system is not part of the laser scanner. It can only be provided in a system via external control software as part of system integration.



SAFE ACCESS GUARDING AT LASHING PLATFORMS (RISK REDUCTION)

Feature	Technology
Safe access guarding at STS lashing platform	Multi-safety light beam, 1D laser

Collision prevention of personnel (pinner) on lashing platform at STS-Crane

The job of a pinner is often dangerous due to limited vision of crane operators and heavy traffic next to, or in the pinning or twistlock area. In many cases pinning on shore side happens below the STS crane. With this kind of operation, a safe area for the pinners is required while hoisting/landing containers. In newer semi-automated operations, a "lashing platform" on a certain high at the crane are installed to minimize the risk to personnel engaged in this operation of not being in close proximity to moving vehicles.

Those lashing platforms provide a traffic free pinning area with reduced risks for serious injury and fatalities. To reduce the risk due to floating loads, a safe access

guarding system for the platform is necessary. First, the lashing platform must be fenced, (hard guarded), to prevent personnel entering the platform from any position. Second an access guard with restart interlock and manual reset function should be installed. A sophisticated and efficient solution is an "optical safety door" for the operative, based on a safety light curtain in a heated outdoor column. When the operative passes the "optical safety door" the hoisting of the container will automatically stop and the lasher can operate safely. After placing or removing the twistlocks, the operatives step back behind the access door, (safety light curtains), and confirm that the platform area is clear by hitting the reset button which is located outside of the dangerous area to restart the container hoisting.



Yard:

Involved equipment:

- Gantry cranes (manually driven RTG, RMG, straddle carrier)
- Automated RMGs
- Intermodal cranes
- Ground transportation vehicles (trucks, terminal tractor, lift trucks, AGVs)

Personnel:

- Truck and terminal tractor drivers
- Container handling equipment drivers
- Checker (e.g. train-checker)
- Maintenance and service staff
- Supervisor

(*) see solution above

GANTRY CRANE – COLLISION PREVENTION SOLUTIONS

Rail Mounted Gantry (RMG), Automated Stacking Crane (ASC) collision prevention solutions

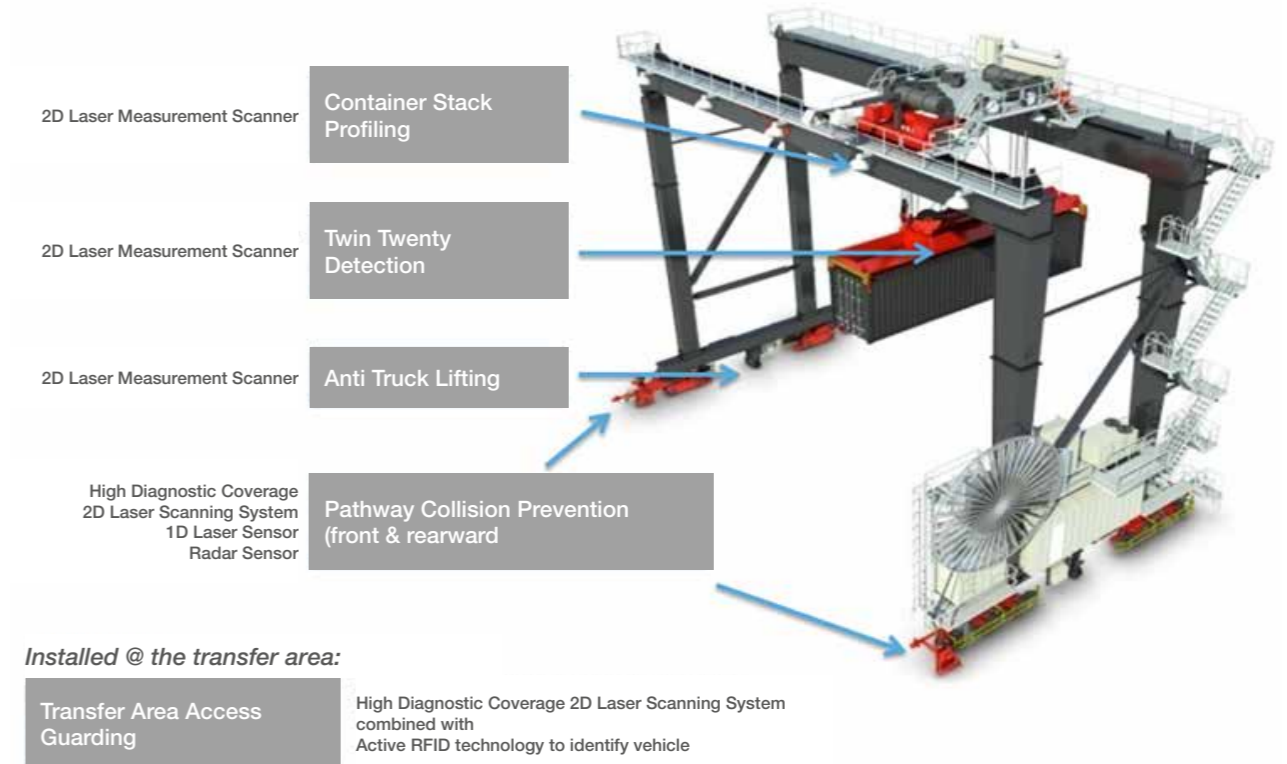

Figure: Collision Prevention Solutions for ASCs

#	Collision Prevention Solutions at RMG, ASC
1	Electronic travel collision prevention
2	Container stack profiling, load collision prevention
3	ASC transfer area access guarding
4	Anti-truck lifting
5	Wheel cover (only secondary collision prevention option)
6	Secondary attachment chain at spreader flipper

ELECTRONIC TRAVEL COLLISION PREVENTION (RISK REDUCTION)

#	Feature	Technology
1	RMG, ASC travel collision prevention and positioning	1D laser sensor
2	RMG, ASC travel collision prevention	Radar sensor* (*depending on area surrounding)
3	RMG, ASC travel collision prevention	2D laser scanner

For uninterrupted operation, and to reduce the likelihood of collision between RMG and ASC cranes and obstacles, an electronic non-contact collision prevention system is mandatory. Due to importance of detecting adjacent cranes, the ability to signal critical distances between cranes via simple alarm outputs from distance sensors is critical. This can be achieved with single-beam laser sensors mounted on the gantry and directed to the adjacent crane. Laser sensors should be able to set alarm thresholds at ranges of about 20m to 30m to match crane stopping distances.

A radar sensor is suitable for sending alarm signals at defined distances, and providing independent alarm outputs for different distance settings.

To process measured distance values effectively, for example to position cranes or approaching cranes in

defined positions, a time-of-flight laser or single-beam long-range distance sensor are recommended. Along with alarm signals at switching outputs at critical distances, the actual distance, (up to 155m), to an adjacent crane is also available via analogue output.

For greater diagnostic coverage, a system for advanced object detection based on 2D laser scanners, combined with a safety controller, can be installed. Along with pre-configured warning and stopping fields for slowdown and crane stop, the system performs automatic self-tests to verify correct sensor function, for example detectability, correct switching action and wire breakages. By placing a laser scanner on each wheel bogie of the crane, collision prevention of crane-to-crane and monitoring the pathway regarding obstacles can be combined.



CONTAINER STACK PROFILING, LOAD COLLISION PREVENTION (RISK REDUCTION)

#	Feature	Technology
1	Gantry crane stack profiling, load collision prevention	2D laser scanner 3D laser scanning system



To facilitate spreader positioning over the container stack, a 2D laser scanner can be installed on the trolley. The trolley position, combined with the distance values of the laser scanner, shows a dynamic 2D-profile of the actual load situation. The generated data, along with the spreader position, assists the crane driver in faster and collision free handling of containers.

As an expansion of driver assistance, an external control software system can use the stack profile information for a "load collision prevention" system to ensure a collision-free spreader drive over the top of the actual container stacks.

A stack profiling function or load collision prevention functionality is not included in the laser scanner. It can be only provided in a system via control software as part of system integration.

Load Collision Prevention System

Laser LCPS can detect container profiles in stacking areas and determine the load position simultaneously

- always with the purpose of preventing collisions. Each system consists of 3D and/or 2D laser scanners (depending on the application), which are mounted at the crane under the trolley platform adjacent to the cabin. While the load is being moved by the crane at each application a "Surveillance Cube" is built around the load within the software, which protects the load until the move is finished. In case of any possible collision or near miss through chimney stacks or misaligned containers in adjacent stacks the system informs the crane PLC (crane control system) to reduce the crane travel speed or even to stop.



ASC TRANSFER AREA ACCESS GUARDING (RISK REDUCTION)

#	Feature	Technology
1	ASC transfer area access guarding	2D laser scanner

Note: Expected vehicles (such as AGVs) can be identified using active RFID.

Transfer areas of automated stacking cranes require access guarding methods because the area could be entered occasionally by manned vehicles (e.g., maintenance vehicles), or any unwanted object. The area requires safe control of the human to automated machine interface and vehicle.

For such kind of outdoor access guarding a system for advanced object detection can be used. The system consists of 2x or 4x 2D laser scanners and a safety controller. Due to self-testing functions via the safety controller, it provides a high degree of diagnostic coverage to reduce the risk of accidents/collisions as much as possible.

A combination of horizontal and skewed vertical monitoring zones, along with logical evaluation of their status, enables the system to deal with different scenarios. Regular and expected vehicles, e.g., container carriers or AGVs, should be able to enter the area without stopping operations. For that, supporting techniques such as active RFID for identification are considered in the evaluation of the system controller. Even if unexpected objects enter the area while an AGV is already present, the system sends an alert to stop dangerous movements. For safety reasons, the system remains in an interlock state which can be released with an external reset button outside the transfer area.

ASC operation with an Automated Guided Vehicle (AGV)

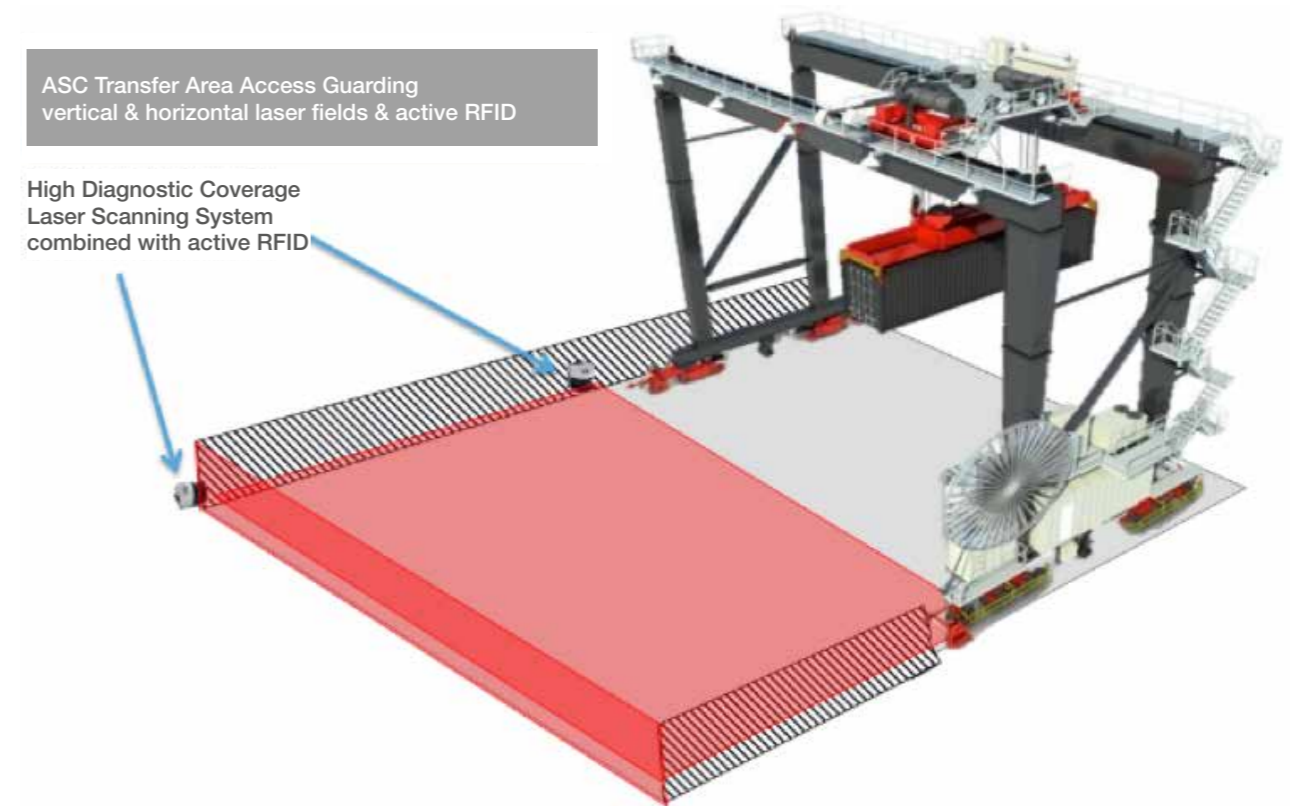

ASC Operation with Shuttle- / Van Carrier (VC)

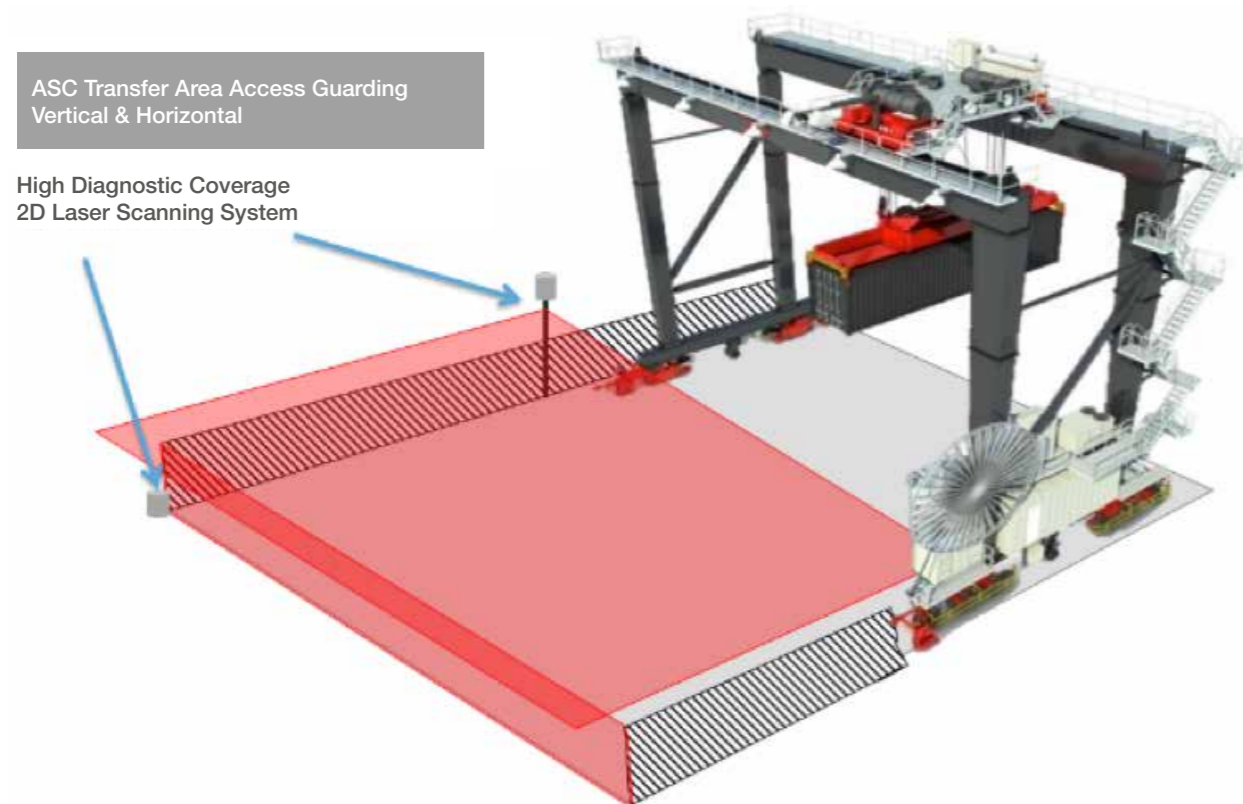

ANTI-TRUCK LIFTING (RISK REDUCTION)

#	Feature	Technology
1	Anti-truck lifting at gantry cranes	2D laser scanner

Unfortunately, twist locks are not always unlocked when cranes start to lift containers from trucks. This results in the accidental lifting of truck chassis and/or entire trucks, which causes damage or injuries when trucks are subsequently dropped. Therefore, a method to detect unwanted truck lifting is highly recommended. 2D laser scanners installed next to gantry crane truck lanes are a simple anti-truck lifting solution.

The laser scanner projects a detection zone above the ground, (approx. 30cm), that monitors the areas

around front and rear truck wheels where the vehicles stop to unload containers. When the spreader is locked to the container and is ready for lifting, the crane controller monitors the status of the laser scanner's monitoring zones. If any zone status of the 2D laser scanner indicates "no object" after lifting has started, this means that the truck wheels have moved out of the zone vertically which indicates that the truck is being lifted along with the container. The crane control will stop hoisting immediately.



RUBBER TIRED GANTRY (RTG) – COLLISION PREVENTION SOLUTIONS

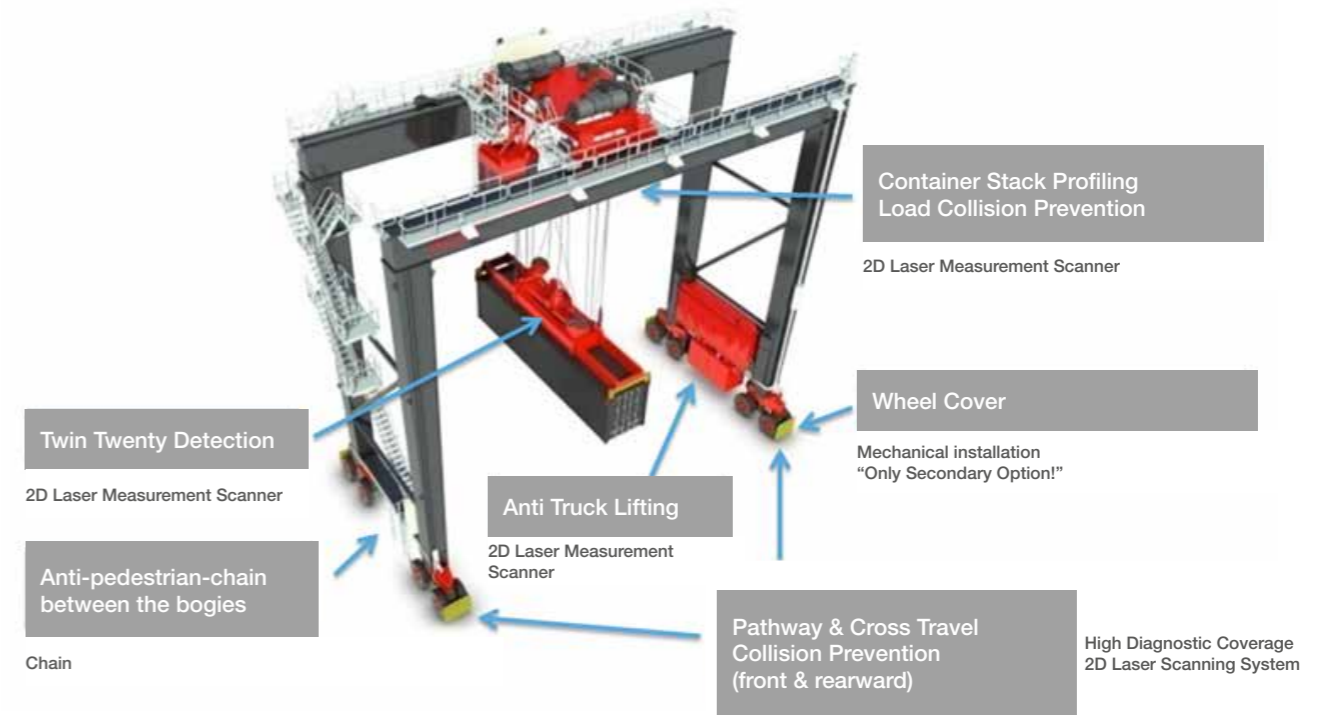

Figure: Collision Prevention Solutions at RTG

#	Collision Prevention Solution at Rubber Tyred Gantry
1	Pathway and cross-travel collision prevention
2	Anti-truck lifting
3	Stack profiling/load collision prevention
4	Twin-twenty detection
5	Wheel cover
6	Secondary attachment chain at spreader flipper
7	Anti-pedestrian chain between the boogies

(RTG) PATHWAY AND CROSS-TRAVEL COLLISION PREVENTION

#	Feature	Technology
1	Pathway and cross-travel collision prevention	2D laser scanner

Similar to ASC gantry cranes, the pathway of an RTG needs to be guarded to prevent collisions with objects, e.g. containers, vehicles or other unwanted obstacles. A system for advanced object detection is a reliable solution for this task. It consists of 4x 2D laser scanners and a safety controller. A laser scanner can be positioned on each wheel bogie to monitor the driveway by covering the entire width of the bogie. The

system provides separate slowdown and stopping signals at the controller to signal the crane drive control. As an extra benefit for the crane operation, thanks to the 270° scanning angle of the 2D laser scanner, the monitoring fields can automatically be switched to the side of the crane for cross-travel mode. Different operating modes are selectable just by an input command from the crane control.



STRADDLE CARRIER (SC) – COLLISION PREVENTION SOLUTIONS



High Diagnostics Coverage 2D Laser Scanning System

Figure: Collision Prevention Solutions at SC

#	Collision Prevention Solution at Straddle Carrier (SC)
1	Pathway and Cross Travel Collision Prevention

(SC) PATHWAY AND CROSS TRAVEL COLLISION PREVENTION

#	Feature	Technology
1	Pathway and Cross Travel Collision Prevention	Laser scanner 2D

Similar to RTG gantry cranes, the pathway of an SC needs to be guarded to prevent collisions with objects, e.g. containers, vehicles or other unwanted obstacles. A system for advanced object detection is a reliable solution for this task. It consists of 4x 2D laser scanners and a safety controller. A laser scanner can be positioned on each wheel bogie to monitor the driveway by covering the entire width of the bogie. The

system provides separate slowdown and stopping signals at the controller to signal the crane drive control. As an extra benefit for the crane operation, thanks to the 270° scanning angle of the 2D laser scanner, the monitoring fields can automatically be switched to the side of the crane for cross-travel mode. Different operating modes are selectable just by an input command from the crane control.

HEAVY LIFT TRUCK – COLLISION PREVENTION SOLUTIONS



Figure: Collision Prevention Solutions at Heavy Lift Truck

#	Collision Prevention Solution at Heavy Lift Truck
1	Rear Drive Assistance at Reach Stacker

REACH STACKER REAR DRIVE ASSISTANCE (RISK REDUCTION)

#	Feature	Technology
1	Rear Drive Assistance	Laser Scanner 2D
2	Rear Drive Assistance	3D Camera
3	Safety Human Tracking System	Safety Active/Passive Tag System

A high percentage of bodily injury claims at ports and terminals are related to lift trucks. Claims involving lift trucks tend to be related to collisions, overturning, or hitting personnel. A very high level of safety risk results from reach stackers' high degree of movement and restricted rear view.

Traffic management should be the key focus to help reduce injuries.

The Reach Stacker Assistance System is an active high precision assistance platform based on 2D laser scanning detection or 3D cameras with active monitoring, (live scan/live video with object marking). Their scope of application supports collisions prevention, (containers, other vehicles,

port infrastructure, personnel). They assist operators in critical maneuvers and provide protection while reversing. If a stacker is approaching an obstacle and the distance is getting critical, the system alerts the operator automatically. Rather than simply being an alarm, the system displays the obstacle on a small touch screen visible to the operator.

An operator display accurately shows all relevant obstacles in outline and in their corresponding warning zones. This gives operators a good understanding of remaining safety distances. The system alerts operators with an audible pre-alarm. If a collision is imminent, the operator will be warned by an audible alarm.



AUTOMATED GUIDED VEHICLE (AGV) – COLLISION PREVENTION SOLUTIONS



Figure: Collision Prevention Solutions at AGV

#	Collision Prevention Solution at Automated Guided Vehicle (AGV)
1	Non-contact travel collision prevention system (safe self-tested)

NON-CONTRACT TRAVEL COLLISION PREVENTION (RISK REDUCTION)

#	Feature	Technology
1	Non-contact Travel Collision Prevention	Laser Scanner 2D

Outdoor 2D laser scanners, combined with a safety controller, provide monitoring zones in the actual drive direction of AGVs, along with regular self-testing. The shape and length of monitoring zones can be changed via input commands to deal with various driving scenarios and speeds.

TECHNOLOGIES FOR COLLISION PREVENTION IN PORTS & TERMINALS

Laser Technology

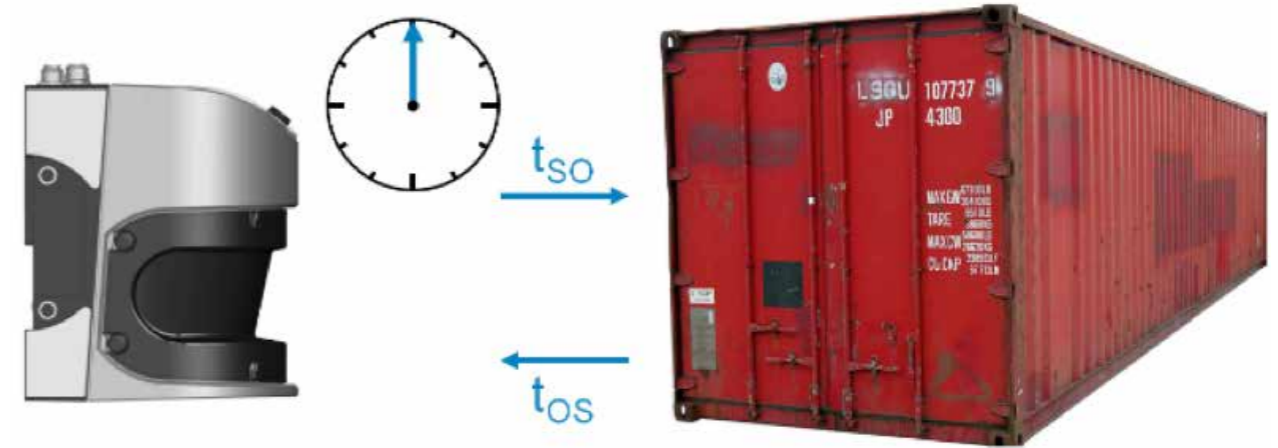

Figure: The TOF principle

The TOF principle:

The laser diode sends a laser-impulse, which triggers the timer. When the laser beam hits a target, (either a natural surface or reflector), some of the light is

reflected. This stops the timer and the time for the beam to travel this distance is used to calculate the distance between the sensor and object.

TYPES OF LASER

There are different types of laser. Each has its place and costs and benefits, depending on the requirements of specific environments.

A) SINGLE DIMENSION (1D) DISTANCE MEASUREMENT

Generally, single dimension (1D) laser meters consist of the following components: laser diode, receiver, optic and a processor with a high-resolution timer.

The measurement frequency of a 1D-laser is up to 20,000 measurements/second, and by averaging several measurements the accuracy can be as high as +/-2 mm.

According to requirements, measurement ranges can vary from a few mm/cm to 1km.

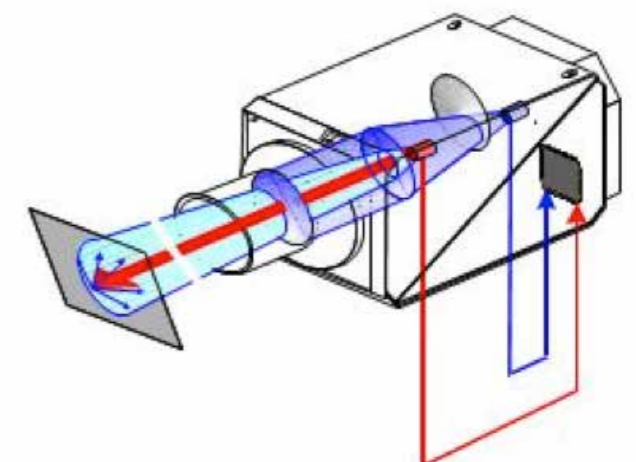

Figure: 1D laser measurement sensor

B) 2D LASER SCANNER

The core of a 2D laser scanner is the same as a 1D laser measurement sensor, but 2D units are fitted with rotating mirrors or glass prisms. Readings from the deflection unit, which combine distance and angle of deflection, can be used with other data to generate a 2D image. The deflection unit rotates depending of the type of sensor used from five to 100Hz. This generates an actualization rate of 200ms down to 10ms, a degree of accuracy comparable to 1D laser sensors.

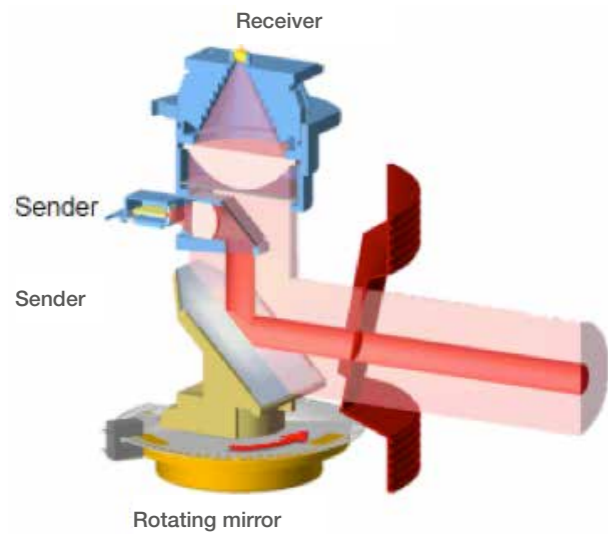

Figure: 2D laser scanner principle

The field of view of a 2D laser scanner can vary depending on laser scanner types. Typically, the following types are used: 70°, 190°, 270° up to 360°

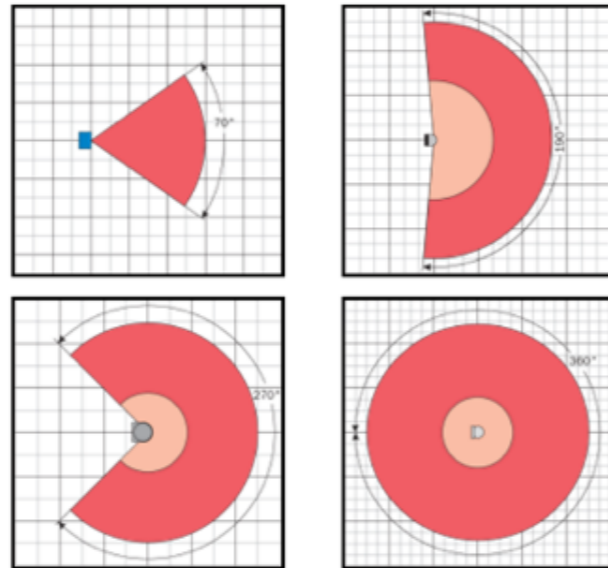

Figure: Laser field of view

The measurement distance of a 2D laser scanner can vary between 10 to 80m.

The detection range depends on the target reflectivity (remission).

A remission of 10 per cent, (a deep black target), is, for safety reasons, the value which is used to describe the safety detection range.

In general, there are two operational modes for 2D laser scanners.

Detection with field evaluation triggers “simple” switching outputs. For example, this function can be used at collision blackspots where warning and stopping fields can be freely configured according to the specific characteristics of a given area.

Ranging uses measurement data from lasers to generate a profile of an environment or object. Used in positioning applications or stack profiling for load collision avoidance.

C) MULTI-LAYER 2D LASER SCANNER

The multi-layer 2D laser scanner has the same function principle as the 2D laser scanner but in multi-scanning layers, (planes), which differ in vertical aperture angles.



Figure: Multi-Layer 2D laser Scanner

A typical application for multi-layer 2D laser scanners is driver assistance.

The data from several simultaneous scanning layers allows, for example, under pitching movements of vehicles, a reliable detection of objects. To guarantee trouble-free and reliable driver assistance in pitching vehicles, multi-layer technology provides a differentiation of ground and object measurements.

D) 3D LASER SCANNING SYSTEM

A 3D laser scanning system works with two different methods to generate a third dimension - either by a rotating 2D laser scanner or through deflection of the laser beam by a second rotating mirror unit.

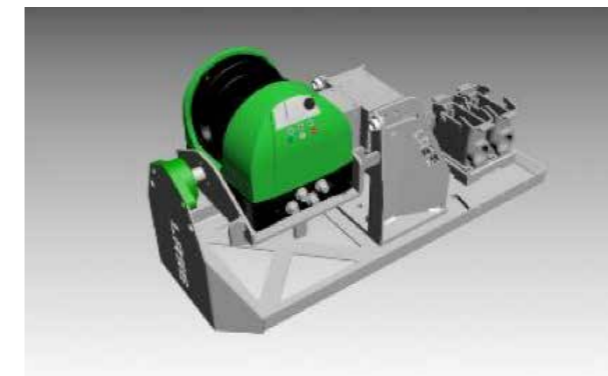

Figure: 3D laser Scanning System

CHOICE OF SENSOR

The accuracy of a sensor can be expressed in terms of distance measurement and the accuracy of deflection angles. When evaluating sensors, key factors that should be considered include:

- Distance (Range)
- Spot size (divergence)
- Angle resolution

Appropriate choices need to be made depending on the application.

Distance

The maximum distance between the sensor and the object should be examined. Typical applications in ports need sensors with a range of at least 30m, sometimes up to 80m.

The distance a laser can measure depends on the reflectivity of the target: white is a good reflecting colour, while black is poor at reflecting light. Sensor suppliers quote different distance values, but it should be noted that while most applications are on natural surfaces, (containers, trailers, etc.), there are occasionally dark surfaces, where the reflectivity of the surface may be as low as 10 per cent.

Divergence (spot size)

The longer the distance between a sensor and an object, the larger the laser spot size. The advantage of a small spot is that small objects can be measured more precisely – for example twist locks or corner castings or vessel antenna.

Beam divergence is measured in mrad = mm/m. The value describes the increase of x mm per m distance. Typically, outdoor scanners have a value from 2.8 up to 15mrad.



Figure: Spot size and divergence

B) 2D LASER SCANNER

The core of a 2D laser scanner is the same as a 1D laser measurement sensor, but 2D units are fitted with rotating mirrors or glass prisms. Readings from the deflection unit, which combine distance and angle of deflection, can be used with other data to generate a 2D image. The deflection unit rotates depending of the type of sensor used from five to 100Hz. This generates an actualization rate of 200ms down to 10ms, a degree of accuracy comparable to 1D laser sensors.

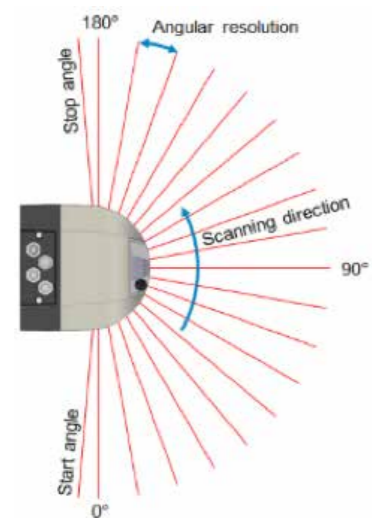

Angle Resolution

The angle resolution describes the angle steps of the rotating units. Typical angle steps are between 0.1° to 1° and these steps have an influence on how accurately the shape of the objects can be seen.

Figure: Angular resolution

THE NEED FOR ROBUST TECHNICAL SOLUTIONS

Ports and terminals are exposed to harsh environmental conditions. Optical sensors and related equipment therefore need to be sufficiently robust withstand weather conditions such as snow, rain, fog, moisture, dust etc., as well as shocks and vibrations.

Multi-Echo Technology

Sender beams used in multi-echo technologies may encounter weather conditions such as rain, fog, dust, etc. Each of these produce a reflection of the sending laser, (echo), which is received by the laser.

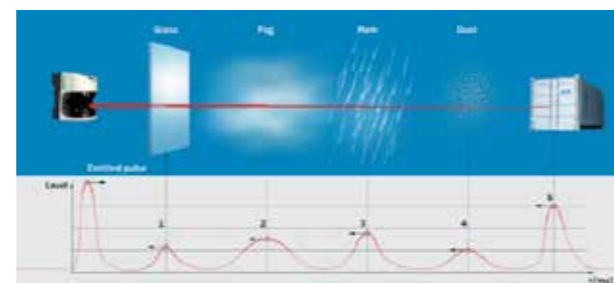

Figure: Multi-echo technology

For example, if the scanner is placed behind glass, as the glass gets dirtier it will start reflecting light back to the receiver and once the level of this reflected light is above a certain level, the first echo will be acknowledged by the scanner. However, depending on filter settings, this echo could be ignored. Multi-echo technology ensures reliable object detection even under unfavourable environmental conditions.

Disturbing objects include:

- Raindrops
- Steam/fog
- Snow
- Dust

By filtering out unwanted echoes, object detection significantly improved.

RECOMMENDED ACCESSORY - WEATHERHOOD

Effects of weather conditions such as snow and rain can be reduced with mechanical solutions like a mounted weatherhood, which reduce the amount of snow and rain that reaches the optic lens. Sunlight is also a disruptive factor for optical systems. Its effects can be significantly reduced by weatherhoods. In hot areas, a weatherhood and sunroof can significantly reduce the effect of sunlight heating sensors above their optimal operating temperatures. Simple weatherhoods and/or sunroofs, (in some areas), are highly recommended.

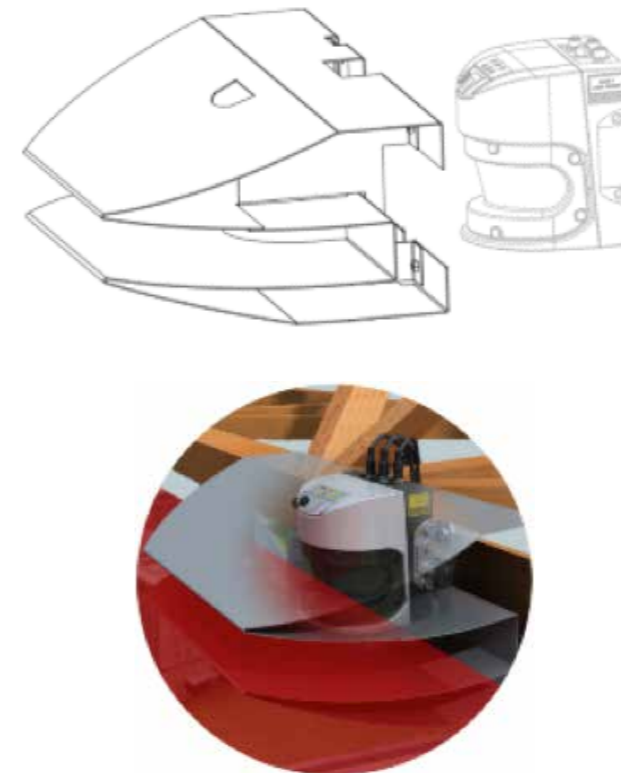

Figure: Weatherhood

Measurement principle

Radar technology measures with its radar cone in a frequency of 24,05 ... 24,25 GHz.

The cone has a dimension in vertical angle and in horizontal angle which have to be known for choose of sensor applications. Further the sensor frequency in some countries requires a specific certification to use for frequency emitting technology.

The sensing range of radar sensors in the port and terminal industry are in the range of detection from 20...40m.

Sensitive radar-based collision avoidance sensors are suitable for ports and terminals applications. Radar's capacity to detect potential collisions is unaffected by weather conditions. The use of weatherhoods, however, is highly recommended for radar units. Low maintenance requirements are another benefit of radar.

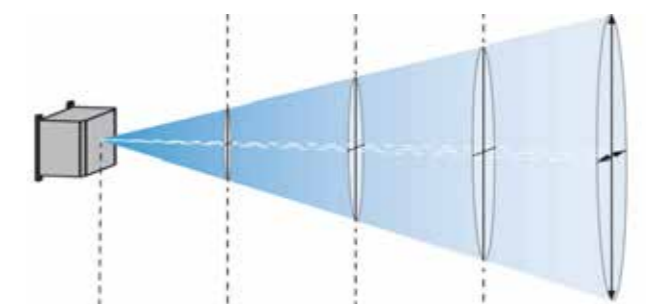

ACTIVE 3D SENSOR WITH INTEGRATED 2D STEREO CAMERA TECHNOLOGY



operator only in the event of critical situations. The built-in data evaluation unit enables reliable detection of outdoor objects.. The sensor works as a stand-alone solution and includes an integrated recording function, which can be used for continuous data recording.

This means that with 3D snapshot technology, operators do not need to constantly check their monitors, as is the case with conventional passive camera systems. 3D snapshot cameras allow operators to focus on key tasks while maintaining awareness of critical situations as they occur.

3D sensors detect relevant objects around their installation points, and provide live feeds. The technology is based on evaluating not only the width, but also the height of objects. Algorithms filter irrelevant information, such as curbs, small stones, rain or fog. This ensures that the operator assistance system only warns the user in critical situations.

Note:

Camera systems, even when they are intelligently designed for harsh environments, are based on optical principles. Their capacity to detect objects is therefore diminished in severe weather conditions or at night.

Please note that an active 3D sensor with integrated 2D stereo camera technology functions as a risk reduction system, and not a collision prevention system.

A 3D stereo camera with active object detection and tracking in near and middle fields.

Robust 3D vision sensors are made for the harsh environmental conditions of ports and terminals.

A live feed alerts the operator with visual and audio signals to override previously defined 3D detection areas. The camera system warns the operator in critical situations.

Snapshot technology using the two-eye principle

3D snapshot cameras record objects around installation points, (e.g. a crane or vehicle), with two images from slightly different perspectives. These images are used to calculate information about distance, representing a third dimension. This is like the way humans perceive space.

The sensor head captures raw 3D data and transmits it to the evaluation unit. This unit is programmed to analyze the vehicle's environment and warn the

ACTIVE RFID



The tags used on helmets, safety jackets, ID cards etc., typically have a service life of three to five years.

Active RFID systems issue audio and visual alerts in real time about the presence and position of personnel and vehicles carrying active tags, and when entering hazardous areas.

RFID systems also provide reporting functions, and dynamic risk analysis tools that allow operations teams to improve safety and efficiency.

Great care must be taken that tags are active, and that battery levels are sufficient. Many terminals now have battery/tag check devices.

Passive RFID tags are also available and widely used. They have some of the same functions as active tags, but are not dependent on battery power.

RFID, (Radio Frequency IDentification), helps decrease the likelihood of collisions involving equipment and personnel.

RFID systems consist of active sensors and radio frequency reflectors.

In most cases, sensors have a detection zone of 360 degrees and an adaptable detection range of three to 40m. Sensors are also available with self-diagnostic capabilities.

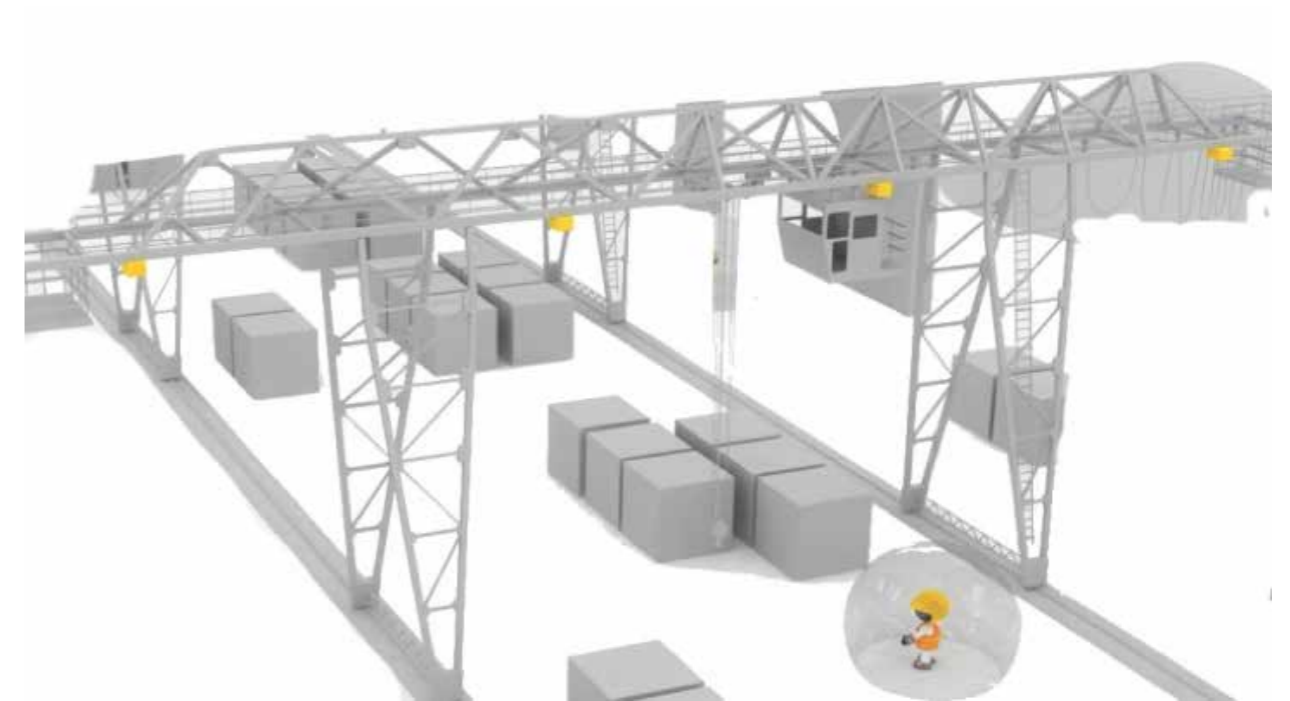

Note:

RFID technologies can be affected by the presence of metal and other cargoes. This means when a tagged person with an active RFID tag is moving or standing between container stacks, or behind a container, long-range sensors would in most cases not detect them. Due to this, RFID tends only to be effective in areas with clear visibility.

Active RFID technologies are only an intelligent assistance system for risk reduction rather than a collision prevention system.

NOT RECOMMENDED FOR COLLISION PREVENTION

The following technology is NOT recommended for risk reduction/collision prevention.

ULTRASONIC TECHNOLOGY

Ultrasonic sensors emit sonic pulses that are reflected by objects being detected. The time required for the pulse to travel from the sensor to the object and back to the sensor is measured, evaluated and converted into a distance.

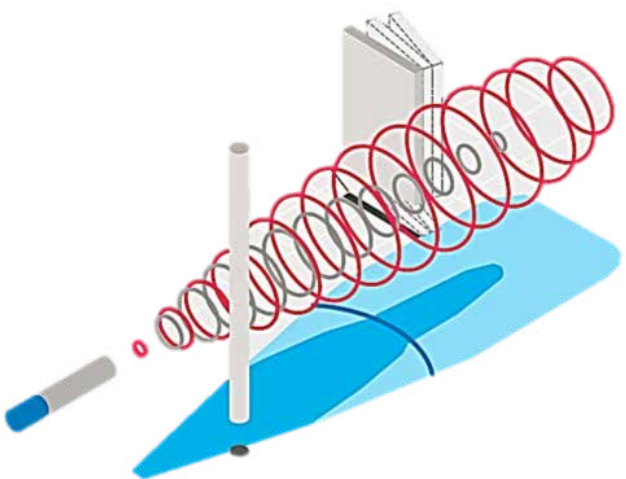

Ultrasonic sensors may appear suitable for preventing collisions because they provide a digital switching output with short- to mid-range detection. Such sensors are also cost efficient.

(Sonic) time-of-flight measurement

However, the detectability and detection range of an object depends very much on its reflective properties. Snow and heavy rain, for example, affect the capacity of sensors to detect obstacles.

Secondly, it is important to note that the behaviour of this technology is also susceptible to degradation by environmental influences such as heavy wind. In such situations, the ultrasonic sound cone can be blown away or misaligned from measuring in the direction where it was initially aligned to detect obstacles. Ultrasonic technologies do not work 100 per cent of the time in harsh environmental conditions.

MECHANICAL INSTALLATIONS – COLLISION PREVENTION SOLUTIONS

The following mechanical features are recommended collision prevention solutions to reduce the risk of accidents and collisions involving personnel, equipment and infrastructure.

RECOMMENDED MECHANICAL FEATURES FOR COLLISION PREVENTION (RISK REDUCTION)



#	Risk	Safety feature	Functional requirement
1	Accidents involving personnel or objects from spreader flippers falling from spreaders.	Spreader flipper fitted with secondary attachment chain.	To prevent spreader flipper fitted with a secondary attachment chain falling if damaged.
2	Collision with personnel walking between quay crane bogies.	Anti-pedestrian-chains between bogies.	The crane fitted with anti-pedestrian-chains between the bogies to prevent bodily injuries.
3	Collision with personnel walking in the last one metre from the side into electronic stopping zone.	Wheel cover plate - only as secondary collision prevention solution	If of personnel detection in front of the gantry wheel while traveling and emergency stop through collision prevention technology is too short a mechanical wheel cover, only as secondary collision prevention option are ok

Table: Mechanical recommended collision prevention solutions at cranes

NOT RECOMMENDED MECHANICAL INSTALLATION FOR BOOM COLLISION PREVENTION AT STS

The following mechanical feature to reduce the risk of a boom to vessel collision is extremely limited because of its fixed mounting next to the boom and not being adaptable to the speed of the crane. The installation of the wire rope provides no warning or slow down output and can “only” provide an emergency stop in a normally fixed position of approx. 1,5m on the side of the boom.

Note: The stopping distance of a max. speed traveling STS crane is not 1.5m (trip wire installed distance to the STS boom), because under the measurement of all the components in the emergency information line it could be up to min. 3.5m.

That means by using only trip wire installation on the STS boom for collision prevention there is still a risk of collisions and subsequent delays/costs when the crane is running under max. travel speed because up to 2m stopping distance is potentially missing

Furthermore, the operator should be informed by warning or by automatic slow-down of travel speed but not stopping in normal cases. It should stop only in emergency situations when a collision appears imminent.

The installation also requires a high degree of mechanical maintenance to prevent being affected by rust and further harsh environmental/weather conditions.



NOTE: In recent years, there have been many collisions between vessels and STS cranes and other crane types. Technology fitted to STS cranes will not prevent such collisions.

It is vital therefore that great care is taken during berthing planning to ensure cranes do not come into contact with vessels manoeuvring. This also, naturally, depends on the skill of the Master and Pilot and the mechanical condition of the vessel.

Extra precautions should be taken in adverse weather conditions, particularly strong winds.

ABOUT THE AUTHORS

This Information Paper has been jointly developed by TT Club, ICHCA International and PEMA with their senior experts according to the information available at the time of publication. It does not constitute professional advice, nor is it an exhaustive summary of the information available on the subject matter to which it refers. This document should always be read and used in conjunction with the relevant national and international legislation and any applicable regulations, standards and codes of practice. This Information Paper provide a comprehensive and state of the art guideline for high level risk reduction and collision prevention at Ports and Terminals.

Every effort is made to ensure the accuracy of the information but neither TT Club, ICHCA International, PEMA, nor any of their members, is responsible for any loss, damage, costs or expenses incurred, (whether in negligence or not), arising from reliance on or interpretation of the data.

For further information on this document:

ICHCA International

Stephan Stiehler, Vice Chairman International
Technical Panel
Director, Stiehler Consulting - International Ports &
Cranes
+49 (0)160 434 7993
consulting@stephanstiehler.com
ichca.com

PEMA

Lars Meurling, Chairman Safety & Environmental
Committee
VP Marketing, Bromma Conquip AB
+46 8 620 09 58
lars.meurling@bromma.com
pema.org

TT Club

Laurence Jones, Director Global Risk Assessment
+61 (0) 413 011 791
laurence.jones@thomasmiller.com

PEMA – Port Equipment Manufacturers Association

Registered Office: p/a Glaverbel Building, Chaussée de la Hulpe 166 Terhulpsessesteenweg,
B-1170 Brussels, Belgium

President & Finance Office: Via S. Balestra 27, CH-6900 Lugano, Switzerland

Finance and Secretariat Office: 15-17 St Cross St, London, EC1N 8UW, United Kingdom

Secretariat Contact Details: Tel: +44 2034 093 100 | Mob: +44 7766 228 958 | Email info@pema.org

TT CLUB 

ICHCA
INTERNATIONAL

PEMA
PORT EQUIPMENT MANUFACTURERS ASSOCIATION

