



National Transportation Safety Board

Contact of Crane Barge *U1510*, Pushed by Towing Vessel *Goose Creek*, with Overhead Powerlines

Accident type	Contact	No. DCA19FM041
Vessel names	<i>Goose Creek</i> and crane barge <i>U1510</i>	
Location	Elizabeth River, Chesapeake, Virginia 36°45.95' N, 076°17.91' W	
Date	June 20, 2019	
Time	1134 eastern standard time (coordinated universal time – 4 hours)	
Injuries	None	
Property damage	\$226,204 est. (transmission lines \$102,487; crane \$123,717)	
Environmental damage	None reported	
Weather	Temperature 84°F, partly cloudy skies, southwesterly winds at 8–10 miles per hour, water temperature 78°F	
Waterway information	Southern Branch of the Elizabeth River. Observed water level at Money Point, 3 miles north of the accident location, was 1.08 feet above mean lower low water at 1136 with 0.3-knot flood current. ¹	

At 1134 local time on June 20, 2019, the crane barge *U1510* (with three persons on board), being pushed by the towing vessel *Goose Creek* (with three crewmembers on board), struck three overhead power transmission lines while transiting to Precon Marine on the southern branch of the Elizabeth River in Chesapeake, Virginia. No pollution or injuries were reported. Damage to the powerlines and crane barge was estimated at \$226,204.



Towing vessel *Goose Creek* and crane barge *U1510* spudded down in Chesapeake, Virginia, after the accident.

¹ Unless otherwise noted, all miles in this report are statute miles.

Contact of Crane Barge *U1510*, Pushed by Towing Vessel *Goose Creek*, with Overhead Powerlines

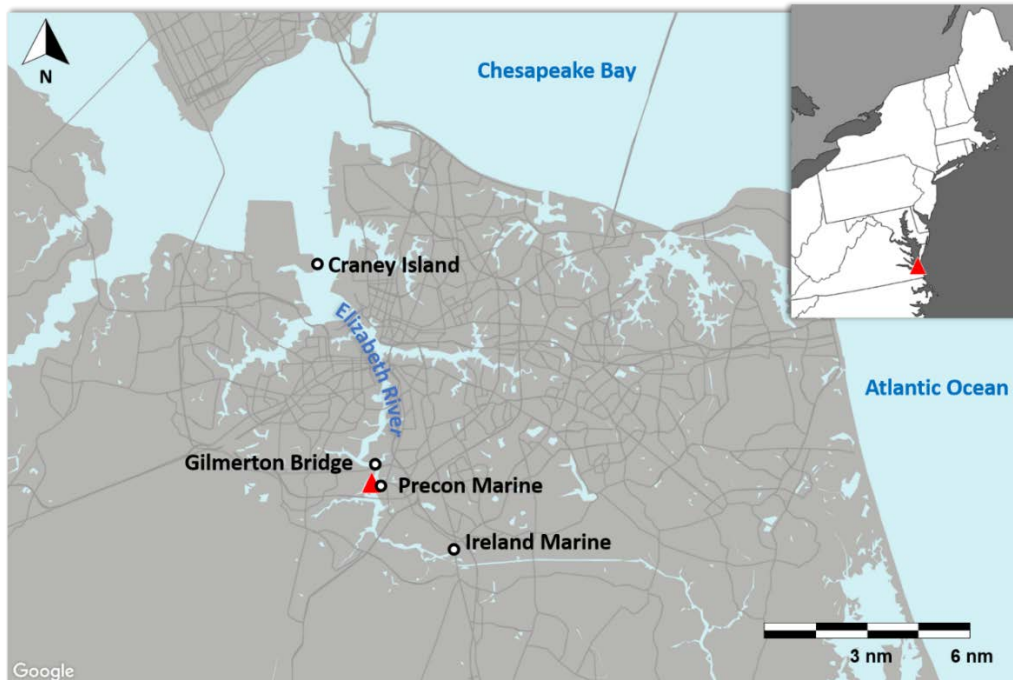

Area of accident location indicated by the red triangle where the *Goose Creek* tow struck the overhead transmission lines. (Background source: Google Maps)

Background

The *Goose Creek*, a 60-foot, twin-propeller towboat, was built in 1981 by Turn Ship Limited of Coden, Alabama, as the *George Burrows* for Spearin Preston and Burrows Inc, located in Staten Island, New York. The vessel was acquired and renamed in 2006 by Century Caretakers LLC and operated by Ireland Marine Transportation Inc of Norfolk, Virginia. The *Goose Creek* was under contractual agreement with Infrastructure and Industrial Constructors Southeast (i+icon Southeast) to transport the crane barge *U1510* from Defense Fuel Support Point, Craney Island, Virginia, to Precon Marine on the Southern Branch of the Elizabeth River in Chesapeake, Virginia, a distance of 9.5 miles. The 150-foot-long spud barge was loaded with a Manitowoc M2250 crane with a 200-foot heavy lift boom, machinery, and three construction employees (a crane operator and two construction workers).²

Accident Events

At 0600 on June 20, 2019, the *Goose Creek* departed Ireland Marine with three crew, including a captain, engineer, and deckhand, en route to Craney Island, Virginia. The company i+icon Southeast was performing project work at Craney Island's North Pier D, constructing a breasting dolphin to increase the capability of the pier to concurrently moor and refuel various classes of naval vessels. The vessel arrived at Craney Island at 0755, and the crew secured the *Goose Creek* face-up and centered to *U1510*'s raked bow with the towing vessel's bow winches, H-bitts, and lines. The *Goose Creek* had a draft of 9 feet, and the barge had a draft of 3.5 feet.

At the same time, the three i+icon Southeast employees on board the crane barge made their final preparations to transit to Precon Marine, about 9.5 miles south down the southern branch

² *Spuds* are steel shafts or through-deck pilings, which are driven into the the seafloor to moor the barge.

Contact of Crane Barge U1510, Pushed by Towing Vessel *Goose Creek*, with Overhead Powerlines

of the Elizabeth River. There, they planned to offload the crane to a larger barge and then return to Craney Island because the breasting dolphin's concrete pilings required a larger platform for the crane to safely perform additional lifts for the project. The crane operator lowered the boom to an angle of 22°, so that its highest point was approximately 10 feet above the *Goose Creek's* wheelhouse and mast, to provide for adequate clearance when passing under the vertical lift, four-lane Gilmerton Bridge, which was manned and operated by employees for the City of Chesapeake, was located about 9 miles south of Craney Island. With the crane's boom lowered to 22°, the crane barge had an air draft of approximately 98 feet.³ In addition, the i+icon Southeast superintendent

and a construction worker planned to follow the tow throughout the three-hour transit in the company's 26-foot workboat, *Heidi C*, to act as an assist tug if needed and support the offloading of the crane.

Precon Marine was located between two sections of overhead high-voltage (115 KV) transmission lines that crossed the Southern Branch Elizabeth River between the Gilmerton Bridge and the I-64 High Rise Bridge. The vertical clearance of these lines was marked on the *Goose Creek* crew's onboard National Oceanic and Atmospheric Administration (NOAA) chart for the area (chart 12253, *Norfolk Harbor and Elizabeth River*). The chart displayed the vertical clearance in feet above mean high water (MHW) of overhead cables for the lowest set of wires. According to the 52nd edition of *U.S. Coast Pilot 3*, this clearance was authorized and permitted by the US Army Corps of Engineers.⁴ The northern section, known as transmission lines no. 120, had a charted vertical clearance of 152 feet and crossed the river north of Precon Marine.

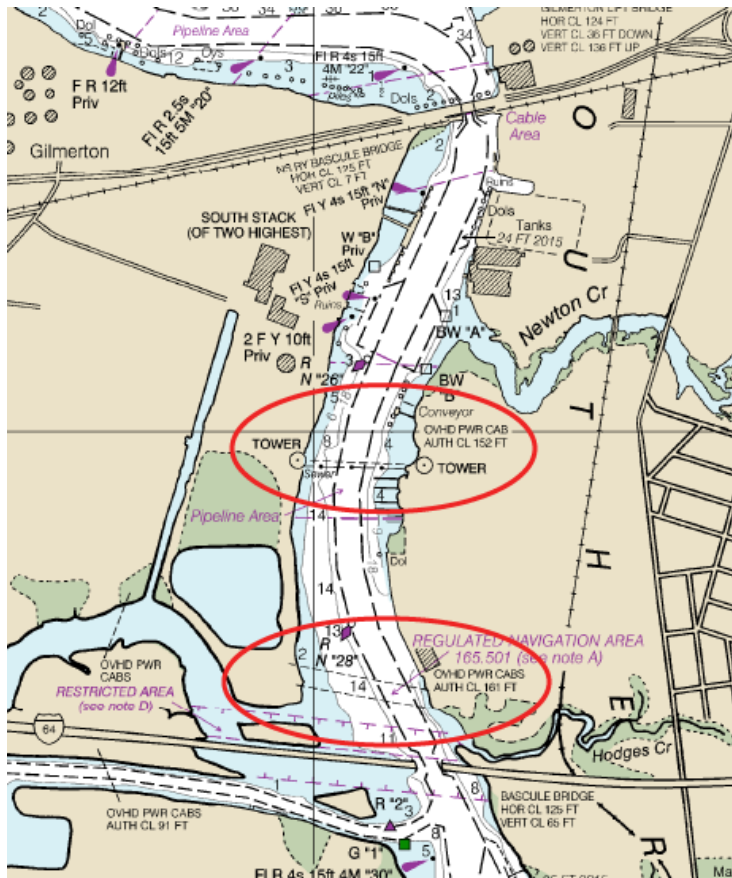

NOAA chart 12253, which the crew used to navigate on board the *Goose Creek*. The powerlines are circled in red. (Annotated by NTSB)

The southern section, lines no. 164, had a charted authorized vertical clearance of 161 feet at MHW and crossed the river between Precon Marine and the I-64 High Rise Bridge. Each transmission line consisted of three conductors, or “phases.”

³ *Air draft* describes the vertical distance from the top of a vessel's highest point down to the waterline.

⁴ *Vertical clearance* is the distance from the water to the lowest point of a bridge or obstruction (in this case, the powerlines).

Contact of Crane Barge *U1510*, Pushed by Towing Vessel *Goose Creek*, with Overhead Powerlines

The captain stated that before the tug and barge got under way, the individuals involved in the transit had a pre-transit discussion. It was established that the superintendent aboard the *Heidi C* would provide direction to the construction workers on board the *U1510* for the offloading of the crane. The superintendent, crane operator, and two construction workers acting as spotters each had a handheld VHF radio and used channel 19 as their primary means of communication amongst themselves and with the *Goose Creek*'s crew.

At approximately 0850, the *Goose Creek* and *U1510* proceeded south from Craney Island en route to Precon Marine. The *Goose Creek* was equipped with an electronic charting system, which the captain was using during the transit. The crane's boom and cab faced aft towards the *Goose Creek*'s wheelhouse, with the barge's box stern as the forwardmost point of the tow. All three crewmembers remained on the *Goose Creek* for the duration of the voyage. The captain did not designate a crewmember as a lookout on the barge or tug.

The tow arrived at the Gilmerton Bridge at 1045 and had to wait on the opening of the adjacent Norfolk Southern no.7 Railroad Bridge because two trains were crossing the tracks. Proceeding behind them was the towing vessel *Island Girl* pushing a single bulk liquid cargo tank barge, *PCS7*, which also had to hold up to await the opening of the bridge. During their wait, the superintendent aboard the *Heidi C* discussed with the *Goose Creek*'s captain over VHF radio channel 19 his intention to get in front of the tow after proceeding through the bridges to locate a suitable position outside of the channel for the tow to spud down (anchor) while they awaited further instruction from Precon Marine for an available berth. The superintendent then radioed the crane operator over the working channel to make preparations to drop a spud to moor the barge and tug outside of the channel.

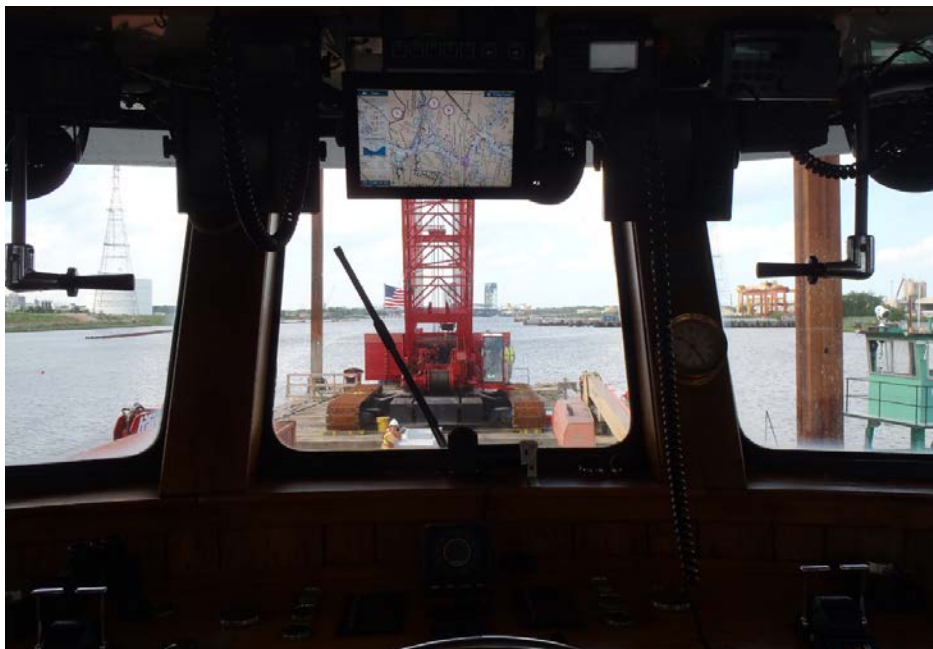

View from *Goose Creek*'s wheelhouse after the accident facing north towards Gilmerton Bridge and no. 120 transmission tower on the left (west) with the Maniwoc crane (centered) and *Heidi C* (right) moored to crane barge *U1510*. (Source: US Coast Guard)

At 1125, the *Goose Creek*'s captain maneuvered the tow through the spans of the Gilmerton Bridge and Norfolk Southern no.7 Railroad Bridge. Shortly thereafter, the *Heidi C* overtook the

Contact of Crane Barge *U1510*, Pushed by Towing Vessel *Goose Creek*, with Overhead Powerlines

tow and passed under the first set of overhead high-voltage transmission lines (no. 120). Meanwhile, the crane operator and spotters on the barge prepared to raise the boom and block assembly. The superintendent on board the *Heidi C* found a location to spud down the barge and communicated over the radio that the tow was to spud down just south of a bundled section of dredge pipes that were secured on the western side of the river outside of the channel. The superintendent radioed the crane operator and instructed him to “boom up and grab the spud.” The crane operator responded and then asked the *Goose Creek*’s captain which of the two spuds the captain preferred to “drop,” to which the captain replied that he did not have a preference. The crane operator decided to pick up the aft starboard spud, which was the closest to the boom and block assembly, while the two spotters prepared the rigging and slings for the spud. The crane operator looked to the west (starboard side) and saw some dredge pipes outside of the cab window as he started to raise the boom. The crane operator did not rotate the crane; therefore, the crane’s boom and cab continued to face aft towards the *Goose Creek*’s wheelhouse throughout the evolution. From this position, the crane operator could not see the upcoming powerlines.

A couple of minutes later, at approximately 1132, as the captain aboard the *Island Girl* overtook *Goose Creek*’s tow on the port side, he radioed the *Goose Creek*’s crew over VHF channel 13 to warn them to “watch the height of the crane’s boom with the overhead powerlines.” The Gilmerton Bridge operator who monitored VHF traffic also overheard this warning on the radio. The *Goose Creek*’s captain immediately radioed i+icon Southeast employees on board the *U1510* and *Heidi C* on channel 19, inquiring about the crane’s boom height. The captain did not take any action to slow the tow and continued on the same course and speed of approximately 3 knots. At this time, the *Goose Creek*’s deckhand reviewed the electronic chart display and NOAA chart 12253 and announced that the first set of power lines had a vertical clearance of 152 feet, which the captain then relayed over channel 19.

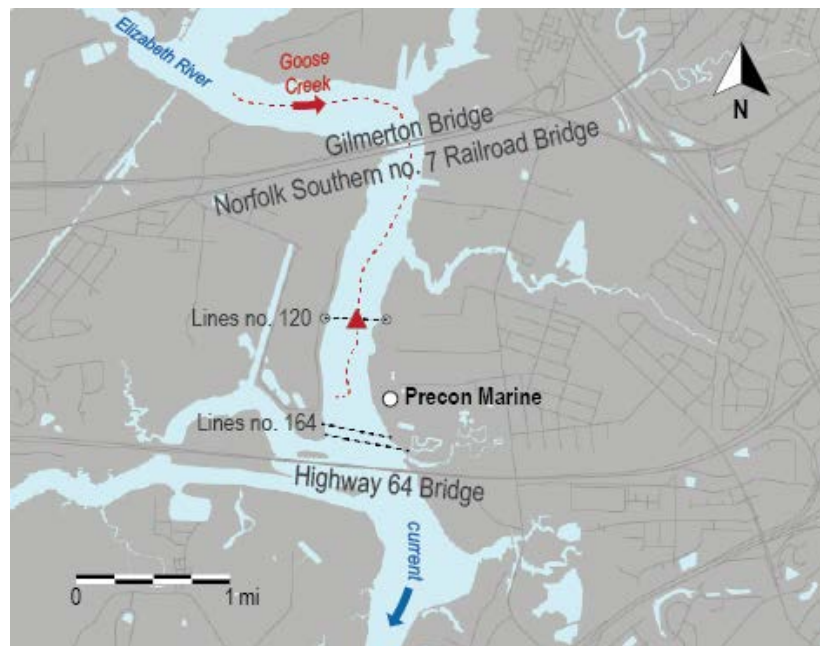

Map of the accident area showing the *Goose Creek* and crane barge *U1510* trackline (red dotted line) crossing under high-voltage transmission lines no. 120 (black dotted lines). (Background source: Google Maps; trackline: terrestrial AIS data)

Contact of Crane Barge *U1510*, Pushed by Towing Vessel *Goose Creek*, with Overhead Powerlines

The *Heidi C* was approximately 400 yards in front of the tow and was adjacent to the northernmost section of land owned by Precon Marine. Out of the forward wheelhouse windows the superintendent saw the second set of transmission lines, no. 164, next to the I-64 High Rise Bridge. He responded to the captain over the radio that “the tow would have about 200 yards of clearance” (horizontal distance from the second set of transmission lines) and they were “good to go.” All of *Goose Creek*’s crew were in the wheelhouse at the time and told investigators that they heard over the radio that, “there was plenty of clearance,” though they could not determine if the response came from the crane operator or superintendent on the *Heidi C*.

The crane operator, who also heard the captain’s call, announced over the radio that he had “200 feet of stick out” (the approximate height of the boom end) and lifted the aft starboard spud slightly for the spotters to remove the spud’s securing pin. To provide the 200-foot boom end height, the crane operator referenced the “Manufacturer Barge Lift Chart” in the crane cab, which indicated the operating radius, boom angle, and boom elevation based on the angle of the crane, which was 67° at the time. He also stated that immediately before the impact he had no awareness of the overhead powerlines. About 1134, the crane’s boom contacted the first of the three conductors (wires) of lines no. 120 that made up the lowest set of transmission lines that crossed the river. After the initial contact, the crane operator started to lower the boom while the two spotters took cover under the telescopic boom lift that was just inboard of starboard spud.

Arc flashes and “cannon like-booms” were observed by several of the crew, construction workers, and shoreside witnesses when each of the three high-voltage phases discharged as a result of the low-impedance connection between the crane’s boom and transmission wire. The horizontal spacing between each wire was 20 feet. The flow of electrical current traveling through the crane caused irremediable damage to the crane’s circuitry and function cut-outs, rendering the operator unable to lower the boom and load hoist.

All three transmission lines subsequently parted and fell into the western side of the river. The captain reversed propulsion on both of *Goose Creek*’s main engines after contacting the first wire, slowing the vessel to 1 knot ahead. There were no reported injuries, and the tow safely moored outside of the channel by the means of a mooring buoy and the barge’s starboard spud.

The City of Chesapeake Police and Fire Department arrived on scene with their fireboat and marine response team. Police Department officers conducted alcohol testing on all personnel involved in the accident. All test results were negative. Postaccident toxicological testing for illegal drugs also yielded negative results for all participants.

The Coast Guard Sector Hampton Roads, Captain of the Port established a temporary closure (safety zone) of the waterway from the Norfolk Southern no. 7 Railroad Bridge to the I-64

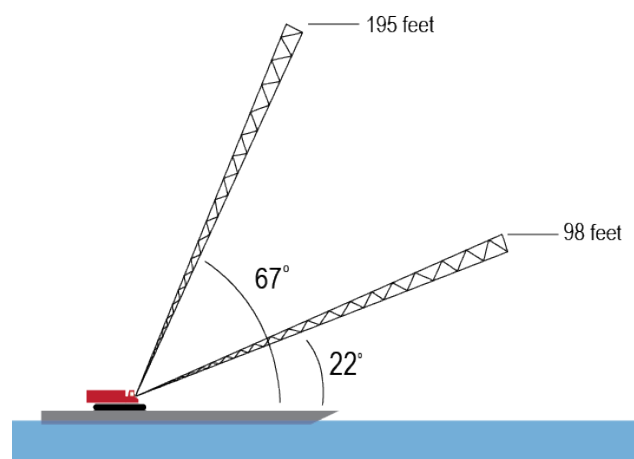

Representation of the Manitowoc M2250 crane on barge *U1510*, with the crane boom elevation shown when stowed at 22° and as determined after the accident with an angle of 67° ; drawing not to scale.

Contact of Crane Barge *U1510*, Pushed by Towing Vessel *Goose Creek*, with Overhead Powerlines

High Rise Bridge and issued several marine broadcasts and marine safety information bulletins detailing the closure until the downed transmission lines were removed later that evening.

Dominion Energy reported power outages to 21,478 customers in Chesapeake and the Virginia Beach area. A Dominion Energy representative initially estimated the damages to the transmission lines at one million dollars; however, the charges as of the publication of this brief totaled \$102,487. Repair damages to the crane totaled \$123,717.

Additional Information

The *Goose Creek's* captain told investigators that he had over 25 years of maritime experience in various capacities, including captain, mate, and able-bodied seaman, aboard similar size tugs and towing vessels. The Coast Guard requirement to operate the *Goose Creek* was an endorsement as coastwise master of towing vessels not more than 100 gross registered tons. However, the captain did not possess a valid Coast Guard merchant mariner credential. The captain also did not provide records or evidence of receiving formal towing vessel training. The *Goose Creek's* operator, Ireland Marine, did not verify the captain's qualifications or merchant mariner credential prior to employment.

The superintendent had over 20 years of experience in marine construction and was brought up from Florida to oversee the project. He stated that i+icon Southeast did not have an "in-house tugboat captain" and needed someone who knew the area, so they contracted Ireland Marine to provide a suitable towboat (the *Goose Creek*) and crew to move the barge to and from the work site.

The *Goose Creek's* last Coast Guard uninspected towing vessel exam was completed on September 25, 2018. The vessel had yet to be issued a Coast Guard Certificate of Inspection (COI) per the recent 46 *Code of Federal Regulations (CFR)* Subchapter M, which was effective in July 2018 for existing towing vessels. There was a phase-in period for vessels to obtain a COI per the regulations.

Subchapter M, Part 140.635 requires the officer in charge of a navigational watch to conduct a navigation assessment for the intended route and operations prior to getting under way, including consideration of "air draft relative to overhead obstructions for the intended route." According to the regulations, "The navigation assessment must be recorded in the towing vessel record, official logbook, or in accordance with the towing safety management system applicable to the vessel."

There was no written evidence that a navigation assessment was conducted prior to departure from Craney Island. In a postaccident interview, the captain told investigators that he conducted a pre-transit discussion, although he was unclear on who attended, but he did not talk about air draft restrictions for the overhead powerlines during the discussion. The superintendent and crane operator told investigators that, prior to their departure from Craney Island, they did not review any paperwork or charts, or have a discussion with the captain to identify potential hazards other than the transit portion through the Gilmerton Bridge and Norfolk Southern no.7 Railroad Bridge. They both stated they knew there were overhead powerlines in the area but did not know the vertical clearance.

Contact of Crane Barge *U1510*, Pushed by Towing Vessel *Goose Creek*, with Overhead Powerlines

Subchapter M regulations also required the operating company to have a towing safety management system (TSMS) or a towing vessel record.⁵ The operating company did not have any written policies or procedures on board the *Goose Creek*. There was also no towing vessel record.

Officers in Charge, Marine Inspection from Sector Hampton Road boarded the *Goose Creek* a day after the accident and identified 22 deficiencies related to the navigation and safety equipment: two related to the plan for the voyage, four to navigation, five regarding survival and lifesaving equipment, and eleven pertaining to maintenance, steering, and electrical power. Inspectors returned to *Goose Creek* on several occasions over the next six months to clear the deficiencies and issued a COI on January 16, 2020.

Analysis

The crane boom's angle indicator read 67° postaccident, indicating the air draft was approximately 195 feet at the time of the accident, which exceeded the charted 152-foot vertical clearance of the transmission lines no. 120 by 43 feet. The captain was aware that the construction workers intended to raise a spud as evidenced by his response to the crane operator's question as to which spud to use for anchoring. The captain and crew were hailed by the *Island Girl*, warning them of the nearby powerlines. However, the captain allowed the construction workers to continue raising the crane boom while approaching the powerlines, and the captain, superintendent, and crane operator all proceeded on the intended route. The captain, who was responsible for ensuring that the vessel was safe to transit the intended route, did not conduct effective voyage planning because he did not consider all overhead obstructions and identify his tow's air draft restrictions for each along the intended route prior to getting under way.

The company did not have any written procedures or policies regarding voyage planning or the consideration of the tow's maximum air draft in conjunction with the vertical clearance of overhead obstacles. Planning and preparation before a tow commences is critically important, including the identification of charted vertical clearance along the route and adherence to operational limits. Although the company did not have voyage planning procedures or policies, the captain stated that he held a pre-transit discussion. However, this discussion proved to be ineffective, since the captain, superintendent, and crane operator were aware of the powerlines but did not take appropriate steps to prevent encroachment, including setting a maximum vertical height (air draft) of the crane when passing under the powerlines prior to the voyage with all involved personnel. Had the company established a TSMS that included voyage planning with requirements for calculating a tow's air draft and identifying all operational restrictions along the route, the crew would have been less likely to raise the boom while transiting.

Under 46 *CFR* Subchapter M, the movement of a towing vessel and its tow must be under the direction and control of a properly credentialed captain, mate, or pilot at all times. The captain did not possess a valid Coast Guard license commensurate with the requirements for the *Goose Creek* (master of towing vessels not more than 100 gross registered tons). There is no indication

⁵ 46 *CFR* Subchapter M, Part 140.910 states that all towing vessels must have a towing vessel record (TVR) or record specified by TSMS: "A towing vessel subject to this section must maintain a TVR or in accordance with the TSMS applicable to the towing vessel. The TVR must include a chronological record of events as required by this subchapter. The TVR may be electronic or paper." Records "must be retained for at least 1 year after the date of the latest entry."

Contact of Crane Barge *U1510*, Pushed by Towing Vessel *Goose Creek*, with Overhead Powerlines

that the company attempted to verify that the captain had the proper credentials or training. Therefore, the company neglected to properly man the *Goose Creek* with a credentialed mariner to command and control the towing operations.

Probable Cause

The National Transportation Safety Board determines that the probable cause of the contact of the towing vessel *Goose Creek's* tow, crane barge *U1510*, with the overhead powerlines was the tow's captain not identifying the risk of raising the boom as the tow approached the powerlines due to the lack of company oversight, demonstrated by the company not implementing a towing safety management system or hiring a properly credentialed mariner to operate the vessel.

Navigation Assessments

Regardless of requirements, planning and preparation before a tow commences is critically important, including the identification of charted authorized overhead vertical clearance along the route. Overhead powerlines pose a risk to vessels and tows with high air drafts. Owners and operators should develop voyage plans that assess operational risks and hazards, to include air draft relative to overhead powerlines and bridges along the intended route.

Vessel Particulars

Vessel	<i>Goose Creek</i>	<i>U1510</i>
Owner/operator	Century Caretakers LLC/ Ireland Marine Transportation Inc	McDonough Marine Service/ i+iconSOUTHEAST
Port of registry	Norfolk, Virginia	New Orleans, Louisiana
Flag	United States	United States
Type	Towing Vessel	Inland Spud Barge
Year built	1981	2017
Official number (US)	634141	532411
IMO number	N/A	N/A
Construction	Steel	Steel
Length	65 ft (19.8 m)	150 ft (45.7 m)
Draft	8.9 ft (2.7 m)	3.5 ft (1.1 m)
Beam/width	23 ft (7.0 m)	55 ft (16.8 m)
Tonnage	99 GRT	534 GRT
Engine power; manufacturer	1250 hp (1676 kW); Caterpillar Marine Diesel	N/A
Persons on board	3	3

NTSB investigators worked closely with our counterparts from Coast Guard Sector Hampton Roads, Virginia throughout this investigation.

For more details about this accident, visit www.nts.gov and search for NTSB accident ID DCA19FM041.

Issued: June 11, 2020

The NTSB has authority to investigate and establish the probable cause of any major marine casualty or any marine casualty involving both public and nonpublic vessels under Title 49 *United States Code*, Section 1131(b)(1). This report is based on factual information either gathered by NTSB investigators or provided by the Coast Guard from its informal investigation of the accident.

The NTSB does not assign fault or blame for a marine casualty; rather, as specified by NTSB regulation, “[NTSB] investigations are fact-finding proceedings with no formal issues and no adverse parties . . . and are not conducted for the purpose of determining the rights or liabilities of any person.” Title 49 *Code of Federal Regulations*, Section 831.4.

Assignment of fault or legal liability is not relevant to the NTSB’s statutory mission to improve transportation safety by conducting investigations and issuing safety recommendations. In addition, statutory language prohibits the admission into evidence or use of any part of an NTSB report related to an accident in a civil action for damages resulting from a matter mentioned in the report. Title 49 *United States Code*, Section 1154(b).